



LEGRABOX

Experience Elegance

[blum.com](https://www.blum.com)

 **blum**[®]



Content

4 **LEGRABOX**

- 6 Technology
- 12 Design
- 14 LEGRABOX pure
- 16 LEGRABOX free
- 20 Programme
- 22 Assembly and installation

24 **AMBIA-LINE**

- 26 Design
- 28 Programme

30 **Applications**

- 32 DYNAMIC SPACE
- 34 Cabinet Solutions
- 36 Modern living

42 **Services for the manufacturer**

44 **Practical assistance**

46 **Order specification**

- 70 Cabinet Solutions
- 84 AMBIA-LINE

92 **Blum**



LEGRABOX

Sophisticated, simple and slim. Experience elegance with LEGRABOX, the box system from Blum. This elegant box system is unprecedented in its level of performance and is characterised by a slim design with straight lines and a particularly high quality of motion. LEGRABOX leads the way with revolutionary technology, functionality and design.

 **blum**

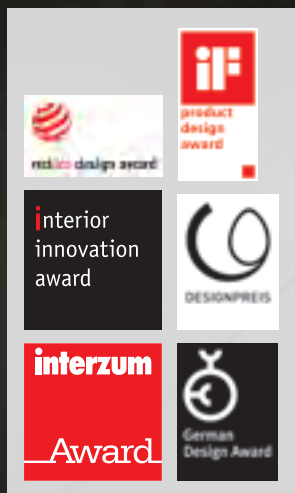

LEGRABOX pure

Superior in quality and design, LEGRABOX pure offers an elegant, high class solution for drawers and pull-outs.



LEGRABOX free

Extending the design options available for LEGRABOX pull-outs is LEGRABOX free offering freedom to individualise furniture interiors.



AMBIA-LINE

AMBIA-LINE offers various options for organising the interior of kitchens and furniture. The inner dividing system is characterised by its narrow frame design complementing LEGRABOX in colour and style.



Fascinating technology

The LEGRABOX cabinet profile exemplifies technology. The runner system provides even greater quality of motion and combines a simple design with excellent runner performance. The innovative runner system offers greater ease of use with minimal opening forces and a synchronised smooth running action from the very first millimetre.

 **blum**[®]

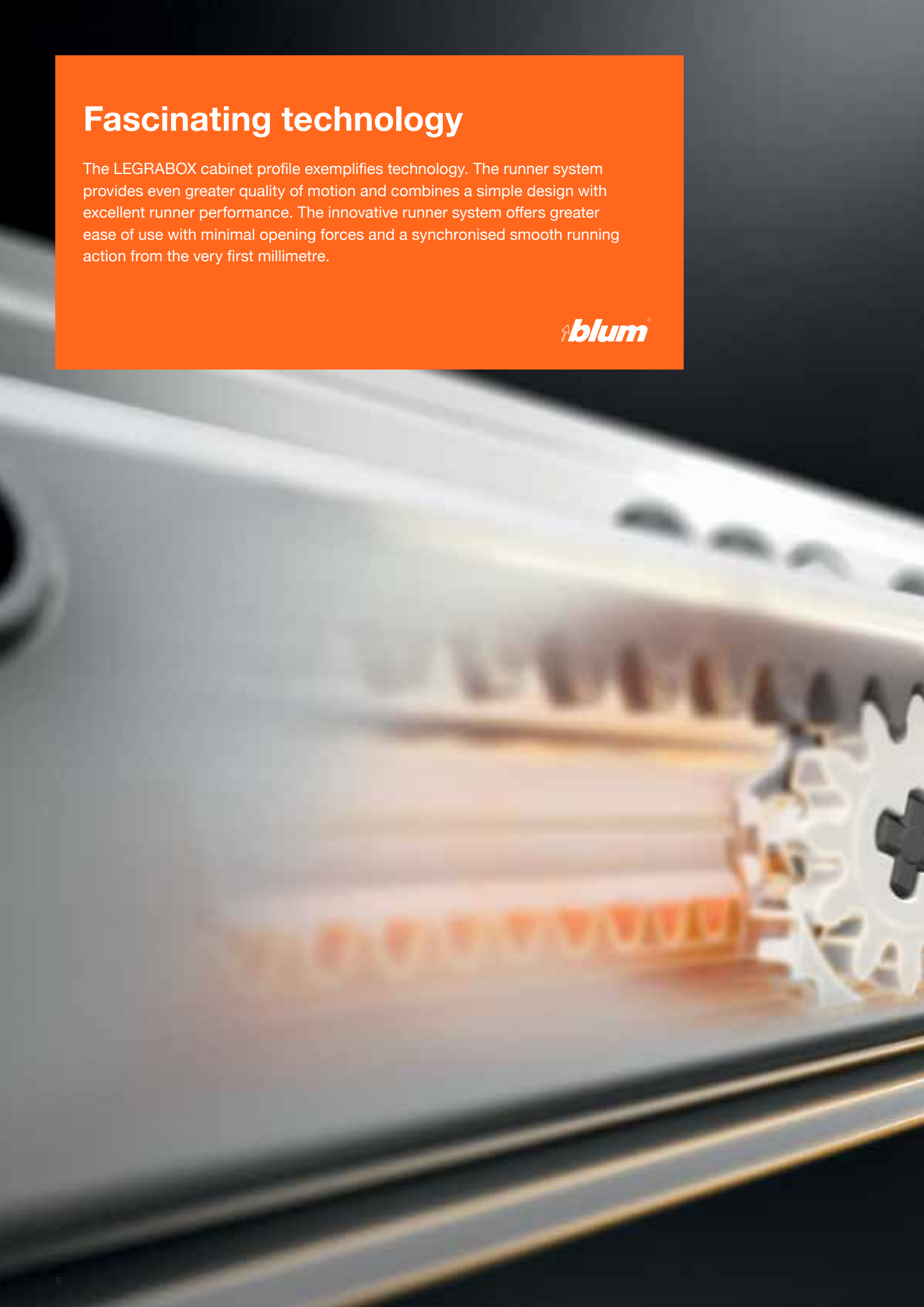

Full carrying capacity

LEGRABOX performs outstandingly even when fully extended and heavily loaded. The high dynamic carrying capacity of 40kg and 70kg provides a wide range of design freedom such as very wide and heavy pull-outs. Thanks to low sag values, solutions with pull-outs positioned at the base of the cabinet are possible.



Stability for high fronts

Extra high fronts that conceal inner drawers and pull-outs are becoming more and more significant as a design element. LEGRABOX supports this design trend with a new type of front fixing bracket that guarantees maximum stability when opening and closing.





Easy assembly

The LEGRABOX front fixing bracket enables fast and above all safe assembly and removal. You just need to place the front in its holding position and it will easily clip into place. The front can even be easily assembled on a pull-out that has already been installed. The 3-dimensional front adjustment positioned on the interior of the drawer side, provides a constant front positioning when closed and a highly constant gap design, irrespective of the front dimension.

 **blum**



Height and side adjustment

For an attractive gap design, the height (+/- 2 mm) and sides (+/- 1.5 mm) can be adjusted with precision using Torx screws.



Tilt adjustment

LEGRABOX can be easily adjusted in three dimensions. NEW: The tilt adjustment is very convenient to perform thanks to its position at the rear on the inside of the drawer side and can be done for drawers as well as pull-outs.



Easy removal

Thanks to the holding position, even very wide fronts can easily be removed by one person alone.

Impressive ease of use

Quality of motion is the driving force behind the entire development and manufacturing of Blum products. LEGRABOX drawers and pull-outs open, move and close effortlessly making furniture easier to operate and provides a higher level of practicality and comfort.

 **blum**



BLUMOTION

BLUMOTION soft-close technology is integrated into the cabinet profile and adapts itself to the size, weight and speed of the closing furniture.



BLUMOTION
by Blum

SERVO-DRIVE

With SERVO-DRIVE electrical motion support, a light touch on the handle-less front or a gentle pull on the handle opens furniture. SERVO-DRIVE is compatible with BLUMOTION soft-close, enhancing comfort and freedom of motion.



SERVO-DRIVE
by Blum

TIP-ON BLUMOTION

Offering functional opening and closing support for handle-less furniture is TIP-ON BLUMOTION, our 100% mechanical opening and soft closing support system. This technology combines two competing forces and makes for a completely harmonious experience when operating drawers and pull-outs.



**TIP-ON
BLUMOTION**
by Blum



Seamless transitions

The new LEGRABOX design supports current living trends. With a selection of four finishes available and four heights to choose from, the box system opens up a wide range of design options. All components of LEGRABOX are perfectly coordinated with one another and form harmonious transitions.



Slimline design

At 12.8mm and straight on the inside and outside, the impressively slim side panels make complete use of the interior.



New colour concept

LEGRABOX features a completely new colour concept made from either anti-fingerprint stainless steel or steel with a matt coating giving it a special feel.



Individual branding

Branding is an integral part of the LEGRABOX pure design and can be printed with your company name or logo.



LEGRABOX pure

Linear. Sleek. Slim. LEGRABOX pure features an elegant drawer side combined with impressive advanced technology. LEGRABOX pure allows for a variety of applications and looks great in any living area whether used with drawer or inner drawers, high fronted pull-outs or inner pull-outs.

blum®

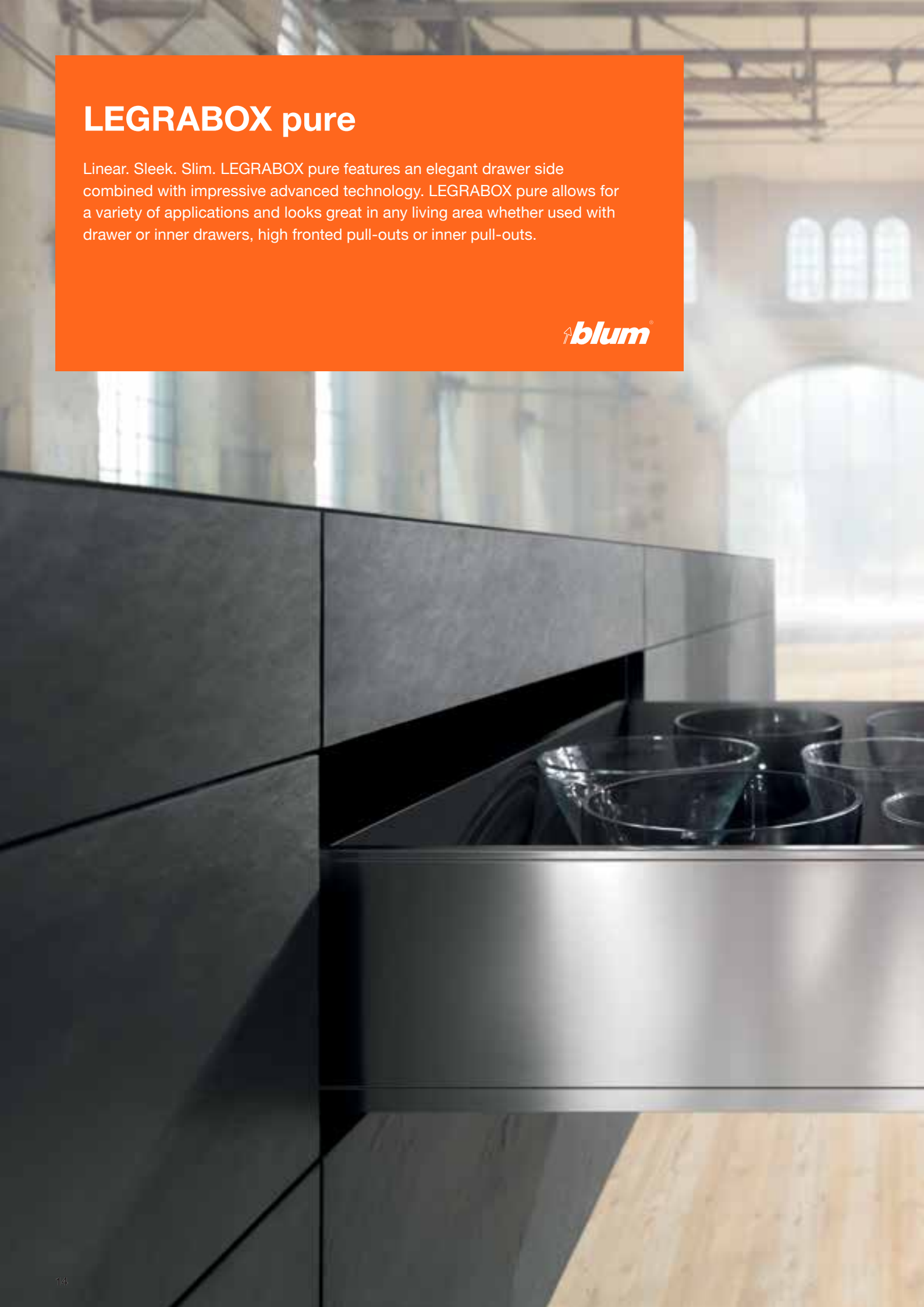



LEGRABOX pure in Anti-fingerprint Stainless Steel in a cutlery and odds and ends drawer application in the kitchen. This features a M height drawer and inner drawer.



LEGRABOX pure in Orion Grey Matt in a kitchen application featuring high fronted F height pull-out with a C height inner pull-out.



LEGRABOX pure C height pull-out in Terra Black Matt in a living room furniture application.

LEGRABOX free

LEGRABOX free, exclusively available for C height pull-outs supports intelligent unique designs in kitchen and living areas. LEGRABOX free allows for large surface area design elements to be integrated harmoniously and effectively into the furniture.

 **blum**





The clear glass design elements ensure an open and light overall appearance and works especially well in our SPACE TOWER cabinet solution.



With LEGRABOX free you can make any piece of furniture unique by integrating design elements made of various materials including glass, wood, leather or stone.



For a harmonious overall concept LEGRABOX free is suitable for use in furniture throughout the home including wardrobe or living room furniture.

Versatile design

With a complementary colour offer, LEGRABOX pure can elegantly be paired with LEGRABOX free.

 **blum**





Universal programme

The LEGRABOX pure programme is versatile and suited to any living area. The box system allows for a variety of applications that can be implemented in different heights and colours.

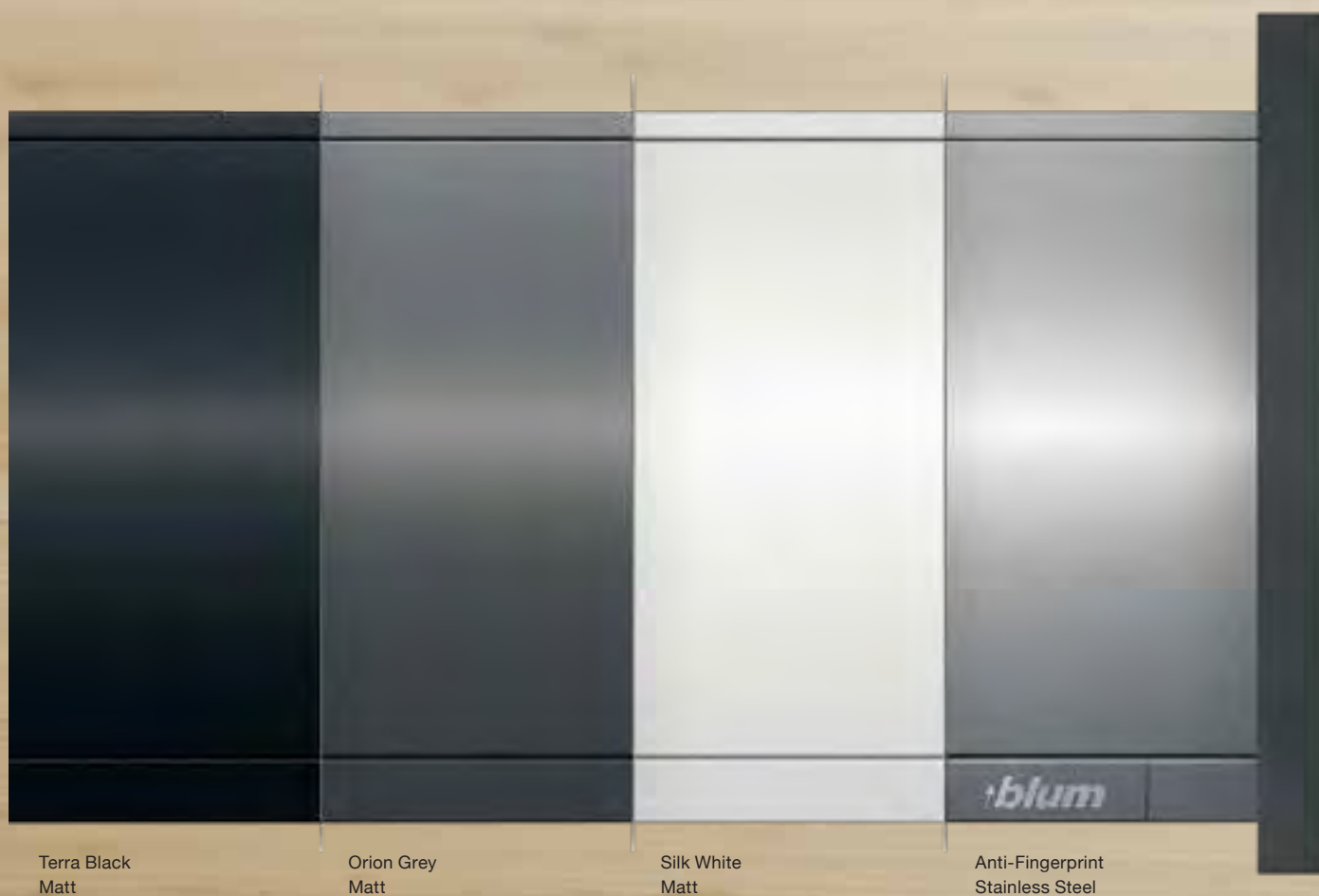

Terra Black
Matt

Orion Grey
Matt

Silk White
Matt

Anti-Fingerprint
Stainless Steel

LEGRABOX pure – drawer and inner drawer



Drawer
Drawer side height M
(90.5 mm)

Nominal lengths

270 mm
350 mm
400 mm
450 mm
500 mm
550 mm
600 mm



Inner drawer
Drawer side height M
(90.5 mm)

Front piece for cutting
to size.



Drawer
Drawer side height K
(128.5 mm)

Nominal lengths

350 mm
400 mm
450 mm
500 mm
550 mm

LEGRABOX pure and LEGRABOX free – high fronted pull-out and inner pull-out



High fronted pull-out
Drawer side height C
(177 mm)

Nominal lengths

LEGRABOX pure

350 mm 500 mm
400 mm 550 mm
450 mm 600 mm

Nominal lengths

LEGRABOX free

450 mm 550 mm
500 mm



Inner pull-out
Drawer side height C
(177 mm)
Front piece* with high
design element



Inner pull-out
Drawer side height C
(177 mm)
Front piece* with low
design element



Inner pull-out
Drawer side height C
(177 mm)
Front piece* with gallery

* Front piece for cutting
to size



High fronted pull-out
Drawer side height F
(241 mm)

Nominal lengths

450 mm
500 mm
550 mm
600 mm

Motion Technologies

The LEGRABOX product range includes Blum's integrated, adaptive dampening system BLUMOTION which ensures it closes silently and effortlessly.

LEGRABOX is compatible with SERVO-DRIVE, Blum's electrical motion support system.

LEGRABOX is available in a version compatible with TIP-ON BLUMOTION mechanical opening and soft closing support system.

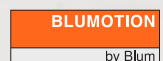

Professional tools

The assembly of LEGRABOX is simple and convenient. Thanks to special assembly devices and templates, LEGRABOX can be assembled and installed precisely and efficiently depending on your needs.

 **blum**





Base router

Ensures easy and precise rebating of the LEGRABOX drawer/pull-out base.



Drilling template for LEGRABOX

For precise pre-drilling on the base and back.



MINISTICK (new)

Facilitates easy and precise drilling for LEGRABOX when using Blum's MINIPRESS P (retrofit option).



BOXFIX E-L

Provides simple yet precise manual assembly of LEGRABOX drawers and pull-outs.



Universal drilling template

The multifunctional assembly device for pre-drilling of fixing positions for cabinet profiles.



Universal drilling template

The multifunctional assembly device for pre-drilling on the drawer front.

AMBIA-LINE

Intuitive and universal, AMBIA-LINE inner dividing system is organisation at its best; extending the timeless elegance of LEGRABOX throughout drawer and pull-out interiors in the kitchen and home. The inner dividing system stands out on account of its slim, streamline design and diverse setting options.

 **blum**[®]



AMBIA-LINE inner dividing system is internationally recognised for its sophisticated design and functional excellence.



reddot design award

interior
innovation
award



German
Design Award

Uniform design

The elegance of LEGRABOX continues throughout kitchen and furniture interiors with AMBIA-LINE inner dividing frames. The narrow, straightforward design of the frames complement LEGRABOX in both colour and style for a harmonious look in all living areas.

 **blum**[®]

Perfect organisation

AMBIA-LINE
creates order within
LEGRABOX with
simple elegance.



Individual adjustment

The flexible cross
dividers can be easily
adjusted to fit the size of
the goods being stored.



Easy utilisation

The frames are easy
to insert and can be
positioned as desired.
Steel frames for the high
fronted pull-out are held
securely by a magnet.



Complete programme

The AMBIA-LINE programme is clear and diverse. AMBIA-LINE frames are compact, versatile and easily positioned in any configuration to suit individual needs, without a need for tools. In addition to the range of narrow frames, a customised cross gallery rail is also available to accommodate specific storage solutions for plastic containers, lids, pots and pans.



Classic steel design

The powder coated steel frames are available in three colours, so drawers and interiors can be made to match.

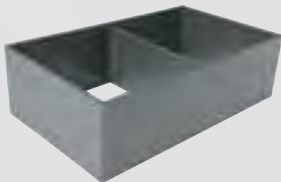

Orion Grey Matt

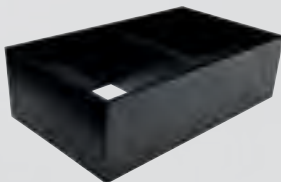

Terra Black Matt



Silk White Matt

AMBIA-LINE for drawers (drawer side heights M and K)



Cutlery insert
Width 300 mm



Drawer frame
for short nominal lengths
of 300 mm or more.
Width 242 mm,
Length 270 mm



Narrow drawer frame
Width 100 mm



Wide drawer frame
Width 200 mm

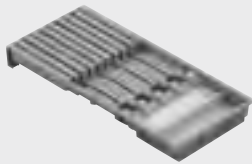

AMBIA-LINE knife holder

Up to nine knives can be stored safely in the knife holder. Suitable for drawer frames with a width of 200 mm.



AMBIA-LINE foil dispenser

Plastic film and aluminium foil can be pulled out and cleanly cut with the film & foil dispenser. Suitable for drawer frames with a width of 200 mm.

AMBIA-LINE for high fronted pull-outs (drawer side heights C and F)



High fronted pull-out frame
for nominal lengths of
270 mm or more.
Width 242 mm,
Length 270 mm



High fronted pull-out frame
for nominal lengths of
400 mm or more.
Width 218 mm,
Length 370 mm



Cross gallery for cutting to
size and lateral divider.



Bottle set for width
100 mm or width 200 mm.

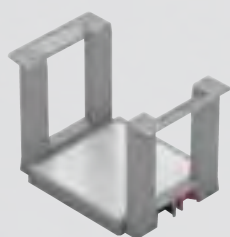

Blum plate holder

Up to 12 plates can be held securely and conveniently transported using the plate holder in the pull-out.

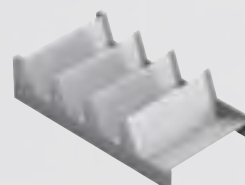

AMBIA-LINE spice holder

All spice containers are stored securely and with a clear overview in the spice holder. Suitable for high fronted pull-out frames with a width of 218 mm (for nominal lengths of 400 mm or more).

Attractive combination

LEGRABOX together with AMBIA-LINE bring sophistication and timeless elegance to the interior of kitchens and furniture throughout the home creating a harmonious overall look in all living spaces.

 **blum**[®]



Practical kitchens

Well designed products like LEGRABOX and AMBIA-LINE bring high levels of functionality to every kitchen. LEGRABOX impresses with its ability to withstand intense daily use for the lifetime of the furniture. AMBIA-LINE is a simple way of creating and enabling fluid work processes.

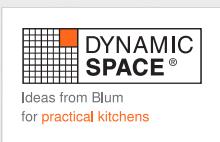

Blum's ideas for practical kitchens

A kitchen has to be fit for everyday use. That's why Blum has been researching the requirements of kitchen users for years. In this way, new ideas for making modern kitchens even more practical are constantly being generated as part of DYNAMIC SPACE. More information can be found at blum.com

Simple workflows

LEGRABOX drawers and pull-outs are fully extendable providing complete overview and easy access right into the back corner. AMBIA-LINE dividers guarantee order and organisation of all stored items such as cooking utensils, bottles and provisions.



Space optimisation

Maximise the use of available space by planning kitchens with wide, high and deep pull-outs. The straight and slim profile of LEGRABOX allows for complete use of the interior. With AMBIA-LINE your customers can organise the space to suit the items being stored.



Top quality motion

With low opening forces, incredibly smooth running action and integrated BLUMOTION soft-close, LEGRABOX increases comfort in the kitchen. Combine with SERVO-DRIVE electrical motion support for superior quality of motion and enhanced user convenience.



Cabinet Solutions

Innovative cabinet solutions ensure available space is optimised. Blum's space saving cabinet solutions create valuable additional storage space without changing the size of the room. The Sink Cabinet, SPACE TOWER and Narrow Cabinets are all achievable with LEGRABOX.

 **blum**



Sink Cabinet

Blum's Sink Cabinet makes optimal use of available space in the cabinet under the sink. Additional usable space is gained via the u-shaped cut out with the Sink Drawer. Also included in the Sink Cabinet is the waste bin pull-out.



SPACE TOWER

Blum's SPACE TOWER is the optimal pantry solution. Utilising fully extendable individual pull-outs, contents are easily accessible from all three sides and into the farthest corner. This solution can also be adapted to suit bedroom wardrobe and living room cabinets.



Narrow Cabinets

Blum's Narrow Cabinets solution makes use of otherwise wasted yet valuable storage space in kitchens. This is especially practical when positioned close to the preparation bench or stove for the bottle and spice storage, carrying up to 20 kgs.



Modern living

LEGRABOX and AMBIA-LINE combine to create a sophisticated storage solution making them the ideal choice for modern furniture design. The clear style looks great in any living area throughout the home.

 **blum**





LEGRABOX pure, drawer side height C in Terra Black Matt, AMBIA-LINE spice holder in high fronted pull-out frame in Terra Black Matt.



LEGRABOX pure, drawer side height C in Silk White Matt, with the Blum plate holder ensure secure storage of plates.



The new AMBIA-LINE bottle drawer solution stores bottles securely. Wider pull-outs offer additional space for chopping boards.



LEGRABOX pure, drawer side height M with AMBIA-LINE cutlery inserts.



LEGRABOX pure waste bin pull-out, AMBIA-LINE frame in Orion Grey Matt for secure storage of cleaning agents.



Plastic containers and matching lids are kept neat and tidy with AMBIA-LINE.

Versatile applications

What has already proven itself in the kitchen is also ideally suited to other living areas. The high quality material of LEGRABOX and AMBIA-LINE makes an elegant addition to any living area.

 **blum**





LEGRABOX pure, drawer side height C, front piece with gallery, in Silk White Matt, AMBIA-LINE frame in Silk White Matt.



LEGRABOX pure, pull-out side height C in Terra Black Matt, AMBIA-LINE frame in Terra Black Matt.



LEGRABOX free, pull-out height C in Silk White Matt with stone design element, AMBIA-LINE frames in Silk white.

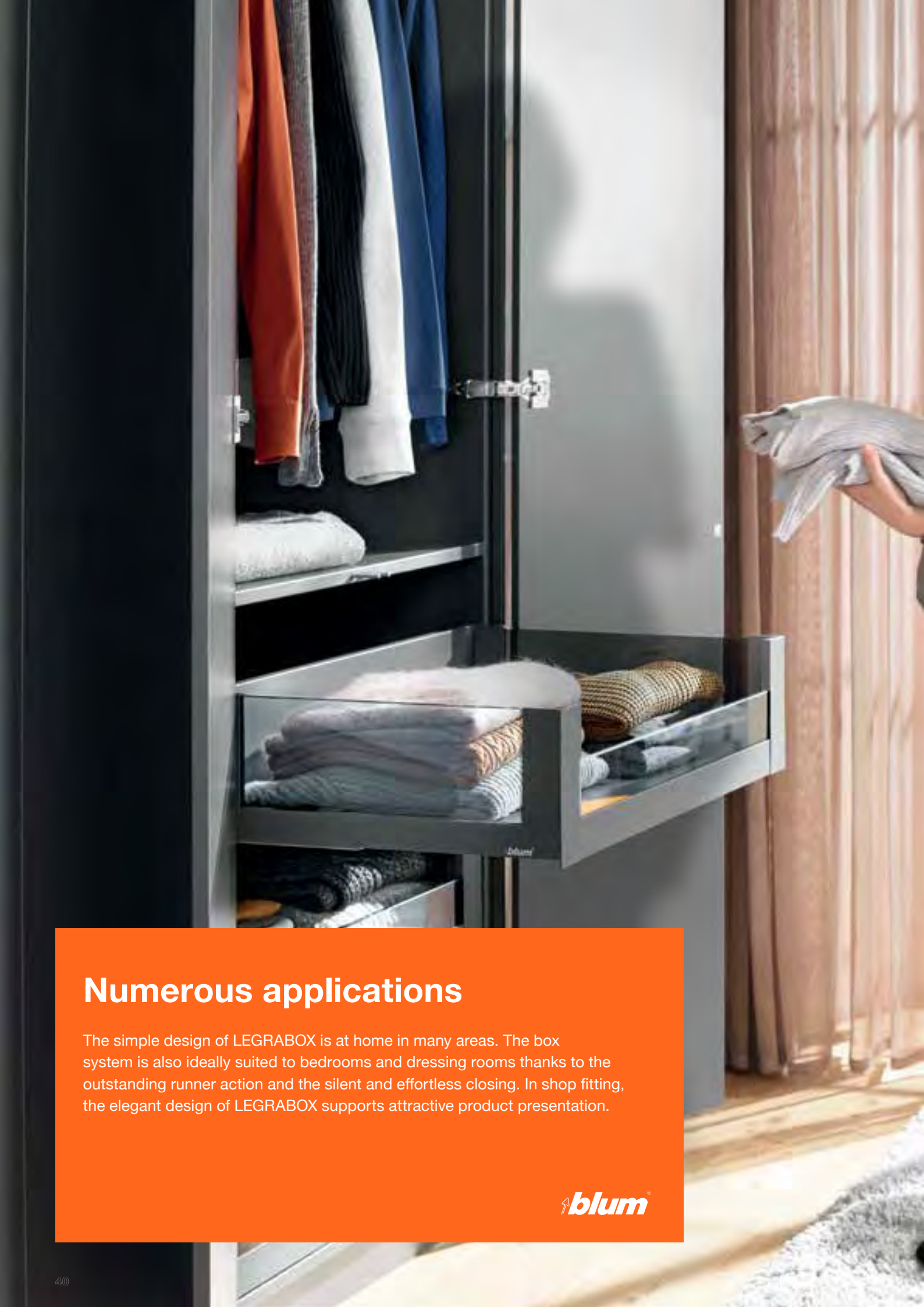

Numerous applications

The simple design of LEGRABOX is at home in many areas. The box system is also ideally suited to bedrooms and dressing rooms thanks to the outstanding runner action and the silent and effortless closing. In shop fitting, the elegant design of LEGRABOX supports attractive product presentation.

 **blum**



LEGRABOX pure, pull-out side C in Silk White Matt, AMBIA-LINE frames in Silk White Matt.



LEGRABOX pure, drawer side height M, AMBIA-LINE drawer frames in Orion Grey Matt.



LEGRABOX pure, drawer side height C in Terra Black Matt, AMBIA-LINE frame in Terra Black Matt.

Services for the Manufacturer

Blum would like to make the ordering, assembly and marketing of its products as easy as possible for our customers and partners. A variety of useful online applications as well as special planning and ordering software are available to support your daily activities.

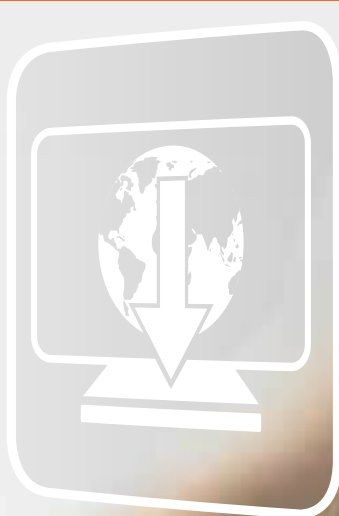

Product Configurator

The Product Configurator assists with the selection and ordering of the correct fittings. Along with parts lists for your desired fitting solution, you also get marketing information, manufacturing and assembly documentation as well as 2D/3D CAD data.

www.blum.com/product-configurator



DYNALOG

Using Blum's DYNALOG planning software, the cabinet planning for Blum fittings is complete and precise. The program can be operated intuitively, automatic collision checks ensure that designs are feasible and do away with trial applications.

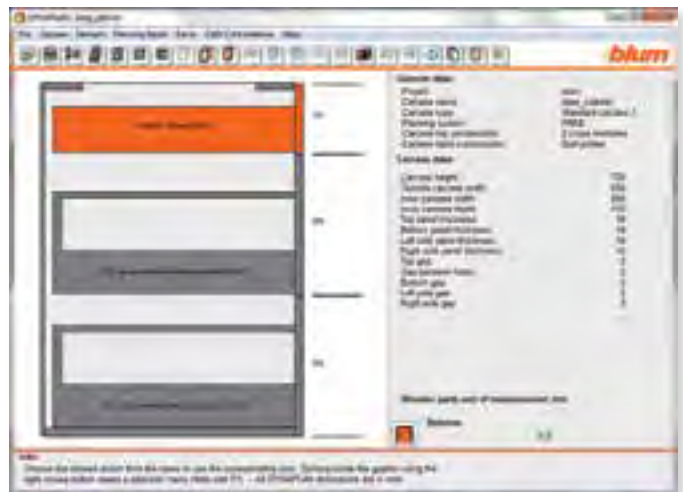

DYNAPLAN interfaces

Complete plans can be exported and imported to or from your CAD or CAM system at the touch of a button via interfaces in DYNAPLAN. In this way, DYNAPLAN supports your main program with both every-day solutions as well as special constructions.



Practical assistance - on-site support

Precision installation and adjustment have an impact on top quality motion. At Blum, we would like to make it as easy as possible for manufacturers, cabinet makers and installers to use Blum products in workshops and on-site. Practical support is provided at every stage of assembly and installation via a useful app, simple assembly instructions and practical templates.

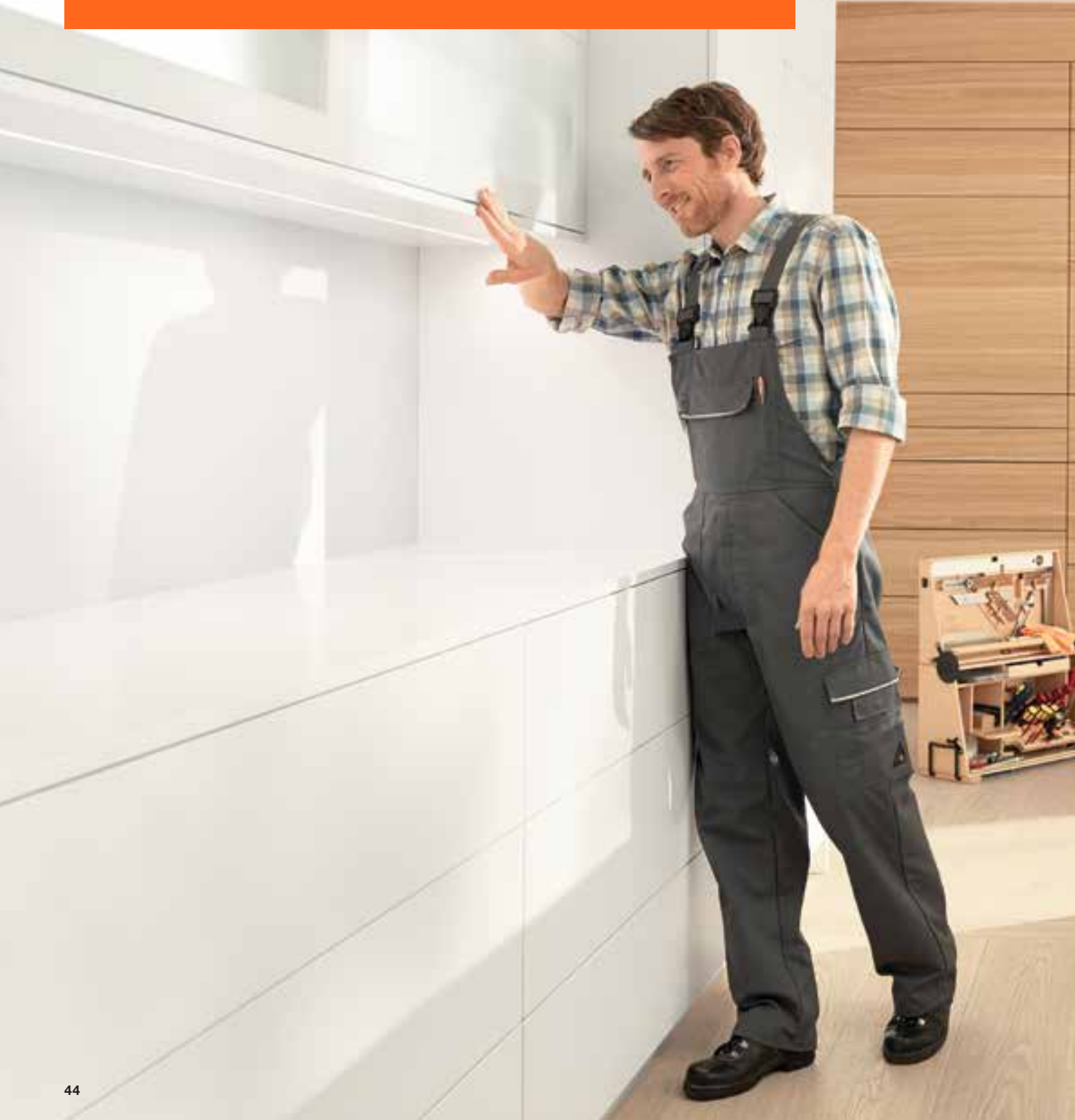

EASY ASSEMBLY App

Blum's complimentary EASY ASSEMBLY App provides cabinetmakers and installers with useful instructions and videos that support on-site assembly, installation and adjustment of Blum fittings.



Simple assembly instructions

Blum products come with easy step-by-step assembly instructions. Assembly and installation instructions can also be found in Blum's trade catalogue and can be downloaded from the Media Centre on Blum's website.



Practical templates

Blum's practical templates are a perfect combination of high precision and practical value. These templates can be used in workshops and are easily transported to support on-site assembly and installation.



LEGRABOX pure
LEGRABOX free



Material and colour

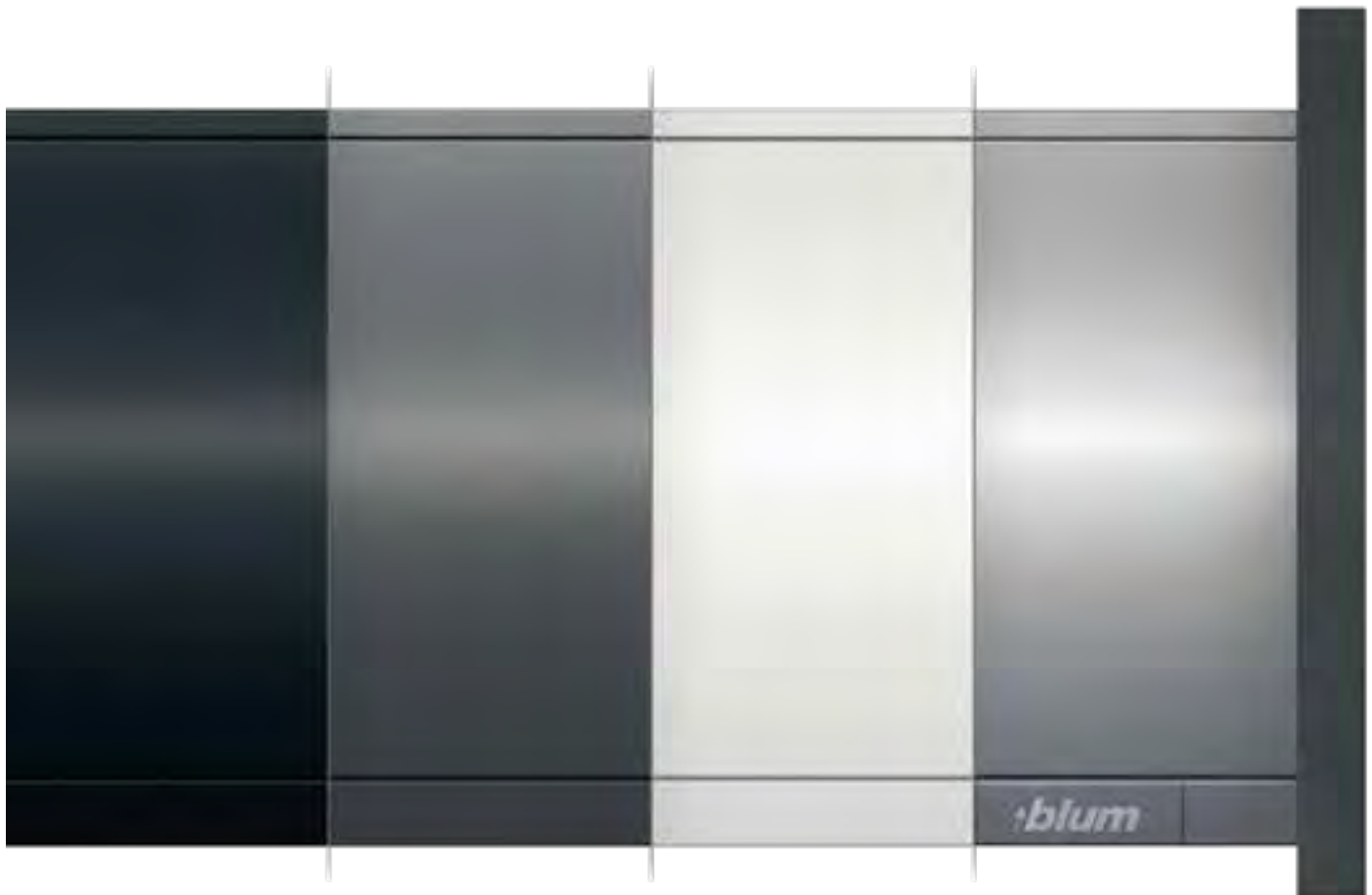

Terra Black Matt

Orion Grey Matt

Silk White Matt

Anti-Fingerprint
Stainless Steel

> Material and colour

	SW-M Silk White Matt	OG-M Orion Grey Matt	TS-M Terra Black Matt	INGL Stainless steel With an anti-fingerprint coating
SW-M Silk White Matt	■			
OG-M Orion Grey Matt		■		
TS-M Terra Black Matt			■	
NI Nickel				■
Nickel Matt				■

Drawer – height M

LEGRABOX pure



Product

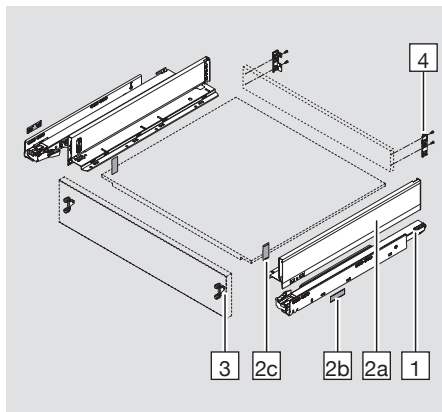

Order specification

1	Cabinet profiles left/right								
	Nominal length	BLUMOTION*				TIP-ON BLUMOTION			
	270 mm	40 kg	750.2701B		40 kg	750.2701M			
	350 mm	40 kg	750.3501B		40 kg	750.3501M			
	400 mm	40 kg	750.4001B		40 kg	750.4001M			
	450 mm	40 kg	750.4501B	70 kg	753.4501B	40 kg	750.4501M	70 kg	753.4501M
	500 mm	40 kg	750.5001B	70 kg	753.5001B	40 kg	750.5001M	70 kg	753.5001M
	550 mm			70 kg	753.5501B			70 kg	753.5501M
	600 mm			70 kg	753.6001B			70 kg	753.6001M

2	Drawer side set				
	Consisting of:				
	2a	drawer side left/right			
	2b	cover caps (external)			
	2c	cover caps (internal)			
		Colour variants			
		SW-M	OG-M	TS-M	INGL
	Nominal length	Steel			Stainless steel**
	270 mm	770M2702S			
	350 mm	770M3502S			
	400 mm	770M4002S			770M4002I
	450 mm	770M4502S			770M4502I
500 mm	770M5002S			770M5002I	
550 mm	770M5502S			770M5502I	
600 mm	770M6002S				

* Suitable for SERVO-DRIVE

** With anti-fingerprint coating

For planning, assembly, installation and adjustment information please refer to Blum's trade catalogue, DYNALOG planning and ordering software, Blum Product Configurator and/or our EASY ASSEMBLY App.

3	Front fixing bracket		
	EXPANDO	2 x	ZF7M70E2
	Screw-on	2 x	ZF7M7002

4	Wooden back fixing brackets left/right				
		Colour variants			
		SW-M	OG-M	TS-M	Nickel
	Height M	Steel			ZB7M000S

Accessories

	Fixing screws for front fixing brackets	
	Ø 3.5 x 15 mm	
	Ø 3.5 x 17 mm	
	Fixing screws for wooden back fixings and drawer sides with drawer base	
	Ø 4 x 15 mm	
	In order to achieve optimal assembly, we recommend that you use flat headed screws.	

	SERVO-DRIVE applications
	For additional components required for SERVO-DRIVE applications refer to page 68

	TIP-ON BLUMOTION
	For additional components required for TIP-ON BLUMOTION applications refer to page 69

Inner drawer – height M front piece closed

LEGRABOX pure



Product

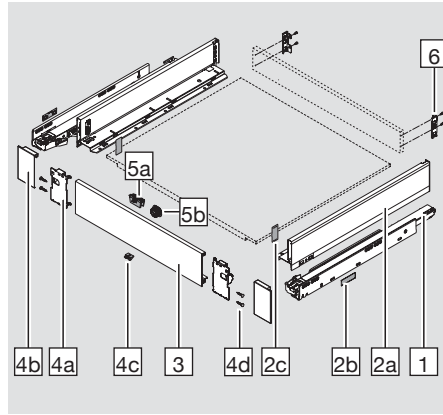

Order specification

1	Cabinet profiles left/right								
	Nominal length	BLUMOTION*				TIP-ON BLUMOTION			
		270 mm	40 kg	750.2701B			40 kg	750.2701M	
	350 mm	40 kg	750.3501B			40 kg	750.3501M		
	400 mm	40 kg	750.4001B			40 kg	750.4001M		
	450 mm	40 kg	750.4501B	70 kg	753.4501B	40 kg	750.4501M	70 kg	753.4501M
	500 mm	40 kg	750.5001B	70 kg	753.5001B	40 kg	750.5001M	70 kg	753.5001M
	550 mm			70 kg	753.5501B			70 kg	753.5501M
	600 mm			70 kg	753.6001B			70 kg	753.6001M

2	Drawer side set				
	Consisting of:				
	2a	drawer side left/right			
	2b	cover caps (external)			
	2c	cover caps (internal)			
		Colour variants			
		SW-M	OG-M	TS-M	INGL
	Nominal length	Steel			Stainless steel**
	270 mm	770M2702S			
	350 mm	770M3502S			
	400 mm	770M4002S			770M4002I
	450 mm	770M4502S			770M4502I
500 mm	770M5002S			770M5002I	
550 mm	770M5502S			770M5502I	
600 mm	770M6002S				

* Suitable for SERVO-DRIVE

** With anti-fingerprint coating

	3 Front piece without groove			
	Colour variants			
	SW-M	OG-M	TS-M	Nickel Matt
	Aluminium			
	For cutting to size	ZV7.1043C01		
	Cutting			
LW - 126 mm				
LW Inner cabinet width				

	4 Front piece set			
	Consisting of:			
	4a Front fixing left / right			
	4b Outer cover caps left/right			
	4c Locking piece			
	4d Screws			
Colour variants				
SW-M	OG-M	TS-M	INGL	
Steel			Stainless steel**	
Z17.0MS0			Z17.0MI0	

	5 Latch set (optional)			
	Consisting of:			
	5a Latch			
	5b Trigger housing (RAL 7037 dust grey)			
	Colour variants			
	SW-M	OG-M	TS-M	TS-M ¹⁾
Plastic				
Z17.0M07				

	6 Wooden back fixing brackets left/right			
	Colour variants			
	SW-M	OG-M	TS-M	Nickel
	Steel			
	Height M	ZB7M000S		

Accessories

	Fixing screws for wooden back fixings and drawer sides with drawer base		
	Ø 4 x 15 mm		
	In order to achieve optimal assembly, we recommend that you use flat headed screws.		

	SERVO-DRIVE applications
	For additional components required for SERVO-DRIVE applications refer to page 68

	TIP-ON BLUMOTION
	For additional components required for TIP-ON BLUMOTION applications refer to page 69

** With anti-fingerprint coating

For Anti-fingerprint Stainless Steel applications, the latch set in Terra Black Matt is recommended.

For planning, assembly, installation and adjustment information please refer to Blum's trade catalogue, DYNALOG planning and ordering software, Blum Product Configurator and/or our EASY ASSEMBLY App.

Drawer - height K

LEGRABOX pure



Product

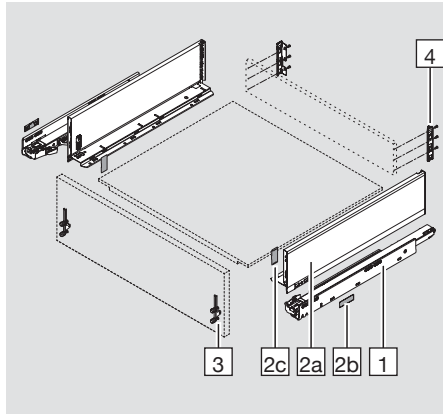

Order specification

1	Cabinet profiles left/right								
	Nominal length	BLUMOTION*				TIP-ON BLUMOTION			
	350 mm	40 kg	750.3501B		40 kg	750.3501M			
	400 mm	40 kg	750.4001B		40 kg	750.4001M			
	450 mm	40 kg	750.4501B	70 kg	753.4501B	40 kg	750.4501M	70 kg	753.4501M
	500 mm	40 kg	750.5001B	70 kg	753.5001B	40 kg	750.5001M	70 kg	753.5001M
	550 mm			70 kg	753.5501B			70 kg	753.5501M

2	Drawer side set			
		Consisting of:		
2a		drawer side left/right		
2b		cover caps (internal)		
2c		cover caps (external)		
		Colour variants		
		SW-M	OG-M	TS-M
		Steel		
	Nominal length			
	350 mm	770K3502S		
	400 mm	770K4002S		
	450 mm	770K4502S		
	500 mm	770K5002S		
	550 mm	770K5502S		

3	Front fixing bracket		
		EXPANDO	2 x
Screw-on		2 x	ZF7K7002

* Suitable for SERVO-DRIVE

4	Wooden back fixing brackets left/right		
	Colour variants		
	SW-M	OG-M	TS-M
	Steel		
	ZB7K000S		
Height K			

Accessories

Fixing screws for front fixing brackets screw-on application	
	Ø 3.5 x 15 mm
	Ø 3.5 x 17 mm
Fixing screws for wooden back fixings and drawer sides with drawer base	
	Ø 4 x 15 mm
	In order to achieve optimal assembly, we recommend that you use flat headed screws.

SERVO-DRIVE applications	
	For additional components required for SERVO-DRIVE applications refer to page 68

TIP-ON BLUMOTION	
	For additional components required for TIP-ON BLUMOTION applications refer to page 69

High fronted pull-out – height C

LEGRABOX pure



Product

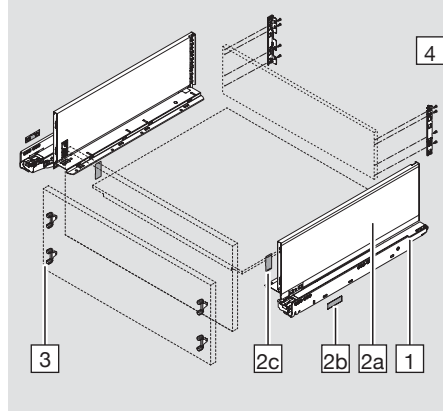

Order specification

1	Cabinet profiles left/right								
	Nominal length	BLUMOTION*				TIP-ON BLUMOTION			
		350 mm	40 kg	750.3501B		40 kg	750.3501M		
	400 mm	40 kg	750.4001B		40 kg	750.4001M			
	450 mm	40 kg	750.4501B	70 kg	753.4501B	40 kg	750.4501M	70 kg	753.4501M
	500 mm	40 kg	750.5001B	70 kg	753.5001B	40 kg	750.5001M	70 kg	753.5001M
	550 mm			70 kg	753.5501B			70 kg	753.5501M
	600 mm			70 kg	753.6001B			70 kg	753.6001M

2	Drawer side set				
	Consisting of:				
	2a drawer side left/right				
	2b cover caps (external)				
	2c cover caps (internal)				
	Colour variants				
		SW-M	OG-M	TS-M	INGL
	Nominal length	Steel			Stainless steel**
350 mm	770C3502S				
400 mm	770C4002S			770C4002I	
450 mm	770C4502S			770C4502I	
500 mm	770C5002S			770C5002I	
550 mm	770C5502S			770C5502I	
600 mm	770C6002S				

* Suitable for SERVO-DRIVE

** With anti-fingerprint coating

LEGRABOX pure



High fronted pull-out – height C

3 Front fixing bracket			
	EXPANDO	4 x	ZF7M70E2
	Screw-on	4 x	ZF7M7002

4 Wooden back fixing brackets left/right					
		Colour variants			
		SW-M	OG-M	TS-M	Nickel
		Steel			
	Height C	ZB7C000S			

Accessories

Fixing screws for front fixing brackets screw-on application	
	Ø 3.5 x 15 mm
	Ø 3.5 x 17 mm
Fixing screws for wooden back fixings and drawer sides with drawer base	
	Ø 4 x 15 mm
	In order to achieve optimal assembly, we recommend that you use flat headed screws.

SERVO-DRIVE applications	
	For additional components required for SERVO-DRIVE applications refer to page 68

TIP-ON BLUMOTION	
	For additional components required for TIP-ON BLUMOTION applications refer to page 69

Inner pull-out – height C – front piece with a high or low design element

LEGRABOX pure



Product

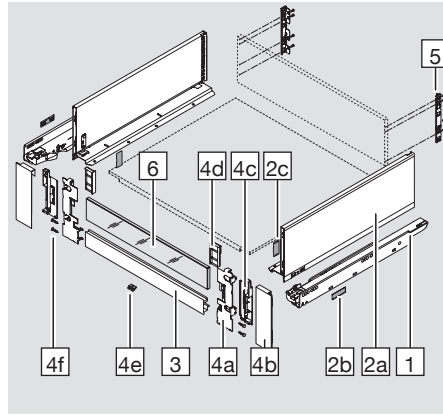

Order specification

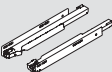
1	Cabinet profiles left/right							
	Nominal length	BLUMOTION*				TIP-ON BLUMOTION		
		350 mm	40 kg	750.3501B		40 kg	750.3501M	
	400 mm	40 kg	750.4001B		40 kg	750.4001M		
	450 mm	40 kg	750.4501B	70 kg	753.4501B	40 kg	750.4501M	70 kg 753.4501M
	500 mm	40 kg	750.5001B	70 kg	753.5001B	40 kg	750.5001M	70 kg 753.5001M
	550 mm			70 kg	753.5501B			70 kg 753.5501M
	600 mm			70 kg	753.6001B			70 kg 753.6001M

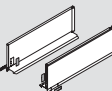
2	Drawer side set				
		Consisting of:			
	2a	drawer side left/right			
	2b	cover caps (external)			
	2c	cover caps (internal)			
		Colour variants			
		SW-M	OG-M	TS-M	INGL
	Nominal length	Steel			Stainless steel**
	350 mm	770C3502S			
	400 mm	770C4002S			770C4002I
	450 mm	770C4502S			770C4502I
	500 mm	770C5002S			770C5002I
	550 mm	770C5502S			770C5502I
	600 mm	770C6002S			

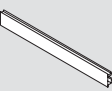
3	Front piece with groove				
			Colour variants		
		SW-M	OG-M	TS-M	Nickel Matt
		Aluminium			
	For cutting to size	ZV7.1043MN1			
	Cutting LW - 126 mm	LW Inner cabinet width			

* Suitable for SERVO-DRIVE

** With anti-fingerprint coating

LEGRABOX pure



Inner pull-out – height C – front piece with a high or low design element

4	Front piece set				
	Consisting of:				
	4a Front fixing left / right				
	4b Outer cover caps left/right				
	4c Interior cover cap left/right				
	4d Adapter piece for low design element left/right				
	4e Locking piece				
	4f Screws				
			Colour variants		
		SW-M	OG-M	TS-M	INGL
		Steel		Stainless steel**	
		Z17.2CS0		Z17.2CI0	

5	Wooden back fixing brackets left/right					
			Colour variants			
			SW-M	OG-M	TS-M	Nickel
			Steel			
	Height C		ZB7C000S			

6	High glass design element (for inner pull-out front)			
	Individually cut to size			Side panel thickness 15 and 16 mm
	Cabinet width			
	450 mm	1 x	ZE7W338G	
	600 mm	1 x	ZE7W488G	
	900 mm	1 x	ZE7W788G	
	1200 mm	1 x	ZE7W1088G	

6	Low glass design element (for inner pull-out front)			
	Individually cut to size			Side panel thickness 15 and 16mm
	Cabinet width			
	450 mm	1 x	ZE7V338G	
	600 mm	1 x	ZE7V488G	
	900 mm	1 x	ZE7V788G	
	1200 mm	1 x	ZE7V1088G	

Accessories

Fixing screws for wooden back fixings and drawer sides with drawer base	
	Ø 4 x 15 mm
In order to achieve optimal assembly, we recommend that you use flat headed screws.	

SERVO-DRIVE applications	
	For additional components required for SERVO-DRIVE applications refer to page 68

TIP-ON BLUMOTION	
	For additional components required for TIP-ON BLUMOTION applications refer to page 69

** With anti-fingerprint coating

For planning, assembly, installation and adjustment information please refer to Blum's trade catalogue, DYNALOG planning and ordering software, Blum Product Configurator and/or our EASY ASSEMBLY App.

Inner pull-out – height C – front piece with gallery

LEGRABOX pure



Product

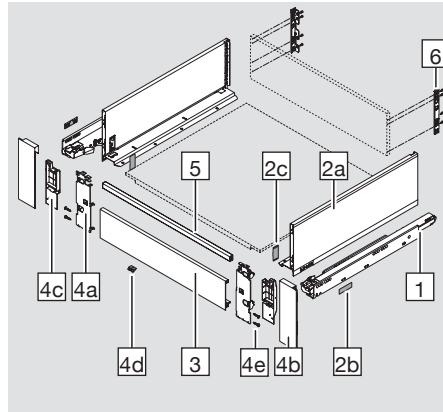

Order specification

1	Cabinet profiles left/right								
	Nominal length	BLUMOTION*				TIP-ON BLUMOTION			
	350 mm	40 kg	750.3501B		40 kg	750.3501M			
	400 mm	40 kg	750.4001B		40 kg	750.4001M			
	450 mm	40 kg	750.4501B	70 kg	753.4501B	40 kg	750.4501M	70 kg	753.4501M
	500 mm	40 kg	750.5001B	70 kg	753.5001B	40 kg	750.5001M	70 kg	753.5001M
	550 mm			70 kg	753.5501B			70 kg	753.5501M
	600 mm			70 kg	753.6001B			70 kg	753.6001M

2	Drawer side set				
	Consisting of:				
	2a drawer side left/right				
	2b cover caps (external)				
	2c cover caps (internal)				
	Colour variants				
		SW-M	OG-M	TS-M	INGL
	Nominal length	Steel			Stainless steel**
	350 mm	770C3502S			
	400 mm	770C4002S			770C4002I
	450 mm	770C4502S			770C4502I
	500 mm	770C5002S			770C5002I
550 mm	770C5502S			770C5502I	
600 mm	770C6002S				

3	Front piece without groove				
	Colour variants				
		SW-M	OG-M	TS-M	Nickel Matt
		Aluminium			
	For cutting to size	ZV7.1043C01			
Cutting	LW - 126 mm	LW			Inner cabinet width

* Suitable for SERVO-DRIVE

** With anti-fingerprint coating

4	Front piece set				
	Consisting of:				
	4a	Front fixing left/right			
	4b	Outer cover caps left/right			
	4c	Interior cover cap left/right			
	4d	Locking piece			
	4e	Screws			
		Colour variants			
		SW-M	OG-M	TS-M	INGL
		Steel			Stainless steel**
		ZI7.3CS0			ZI7.3CI0

5	Cross gallery				
		Colour variants			
		SW-M	OG-M	TS-M	Nickel Matt
		Aluminium			
	For cutting to size	ZR7.1080U			
	Cutting LW - 90 mm	LW	Inner cabinet width		

6	Wooden back fixing brackets left/right				
		Colour variants			
		SW-M	OG-M	TS-M	Nickel
		Steel			
	Height C	ZB7C000S			

Accessories	
Fixing screws for wooden back fixings and drawer sides with drawer base	
	Ø 4 x 15 mm In order to achieve optimal assembly, we recommend that you use flat headed screws.

SERVO-DRIVE applications	
	For additional components required for SERVO-DRIVE applications refer to page 68

TIP-ON BLUMOTION	
	For additional components required for TIP-ON BLUMOTION applications refer to page 69

** With anti-fingerprint coating

High fronted pull-out – height C

LEGRABOX free



Product

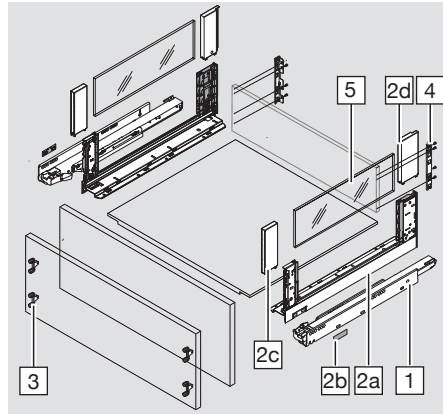

Order specification

1	Cabinet profiles left/right								
	Nominal length	BLUMOTION*				TIP-ON BLUMOTION			
	450 mm	40 kg	750.4501B	70 kg	753.4501B	40 kg	750.4501M	70 kg	753.4501M
	500 mm	40 kg	750.5001B	70 kg	753.5001B	40 kg	750.5001M	70 kg	753.5001M
	550 mm			70 kg	753.5501B			70 kg	753.5501M

2	Drawer side set				
		Consisting of:			
2a		drawer side left/right			
2b		cover caps (external)			
2c		BOXCOVER front			
2d		BOXCOVER back			
		Colour variants			
		SW-M	OG-M	TS-M	INGL
		Steel			Stainless steel**
	Nominal length				
	450 mm	780C4502S		780C4502I	
	500 mm	780C5002S		780C5002I	
	550 mm	780C5502S		780C5502I	

3	Front fixing bracket		
		EXPANDO	4 x
Screws		4 x	ZF7M7002

* Suitable for SERVO-DRIVE

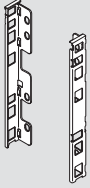

** With anti-fingerprint coating

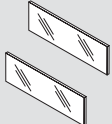
	4 Wooden back fixing brackets left/right			
	Colour variants			
	SW-M	OG-M	TS-M	Nickel
	Steel			
Height C	ZB7C000S			

	5 Glass design element (side)		
	Nominal length		
	450 mm	1 x	ZE7S338G
	500 mm	1 x	ZE7S388G
550 mm	1 x	ZE7S438G	

Accessories

	Transportation lock for design element (side)		
	For transporting pre-assembled design elements (side)		
		per pull-out x 2	780C0009

	Fixing screws for front fixing brackets		
	Ø 3.5 x 15 mm Ø 3.5 x 17 mm		
	Fixing screws for wooden back fixings and drawer sides with drawer base		
	Ø 4 x 15 mm		
	In order to achieve optimal assembly, we recommend that you use flat headed screws.		

SERVO-DRIVE applications	
	For additional components required for SERVO-DRIVE applications refer to page 68

TIP-ON BLUMOTION	
	For additional components required for TIP-ON BLUMOTION applications refer to page 69

Inner pull-out – height C – front piece with a high or low design element

LEGRABOX free



Product

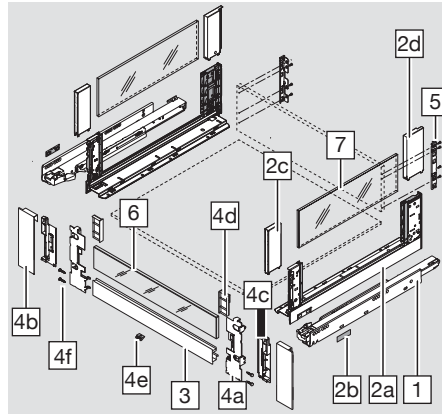

Order specification

1	Cabinet profiles left/right								
	Nominal length	BLUMOTION*				TIP-ON BLUMOTION			
	450 mm	40 kg	750.4501B	70 kg	753.4501B	40 kg	750.4501M	70 kg	753.4501M
	500 mm	40 kg	750.5001B	70 kg	753.5001B	40 kg	750.5001M	70 kg	753.5001M
	550 mm			70 kg	753.5501B			70 kg	753.5501M

2	Drawer side set			
		Consisting of:		
2a		drawer side left/right		
2b		cover caps (external)		
2c		BOXCOVER front		
2d		BOXCOVER back		
		Colour variants		
		SW-M	OG-M	TS-M
	Nominal length	Steel		Stainless steel**
	450 mm	780C4502S		780C4502I
	500 mm	780C5002S		780C5002I
	550 mm	780C5502S		780C5502I

3	Front piece with groove				
			SW-M	OG-M	TS-M
		Aluminium			
For cutting to size		ZV7.1043MN1			
Cutting	LW - 126 mm	LW	Inner cabinet width		

* Suitable for SERVO-DRIVE

** With anti-fingerprint coating

LEGRABOX free



Inner pull-out – height C – front piece with a high or low design element

4		Front piece set			
	Consisting of:				
	4a	Front fixing left / right			
	4b	Outer cover caps left/right			
	4c	Interior cover cap left/right			
	4d	Adapter piece for low design element left/right			
	4e	Locking piece			
	4f	Screws			
		Colour variants			
		SW-M	OG-M	TS-M	INGL
		Steel			Stainless steel**
		Z17.2CS0			Z17.2CI0

5		Wooden back fixing brackets left/right				
			SW-M	OG-M	TS-M	Nickel
			Steel			
Height C		ZB7C000S				

6		High glass design element (for inner pull-out front)			
	Individually cut to size		Side panel thickness		
	Cabinet width		15 and 16 mm		
	450 mm	1 x	ZE7W338G		
	600 mm	1 x	ZE7W488G		
	900 mm	1 x	ZE7W788G		
1200 mm	1 x	ZE7W1088G			

6		Low glass design element (for inner pull-out front)			
	Individually cut to size		Side panel thickness		
	Cabinet width		15 and 16 mm		
	450 mm	1 x	ZE7V338G		
	600 mm	1 x	ZE7V488G		
	900 mm	1 x	ZE7V788G		
1200 mm	1 x	ZE7V1088G			

7		Glass design element (side)			
	Nominal length				
	450 mm	1 x	ZE7S338G		
	500 mm	1 x	ZE7S388G		
	550 mm	1 x	ZE7S438G		

** With anti-fingerprint coating

Inner pull-out – height C – front piece with a high or low design element

LEGRABOX free





Order specification

Accessories

Transportation lock for design element (side)		
	For transporting pre-assembled design elements (side)	
		per pull-out x 2
		780C0009

Fixing screws for wooden back fixings and drawer sides with drawer base		
	Ø 4 x 15 mm	
	In order to achieve optimal assembly, we recommend that you use flat headed screws.	

SERVO-DRIVE applications	
	For additional components required for SERVO-DRIVE applications refer to page 68

TIP-ON BLUMOTION	
	For additional components required for TIP-ON BLUMOTION applications refer to page 69

LEGRABOX free



Inner pull-out – height C – front piece with gallery

Product



Space requirement

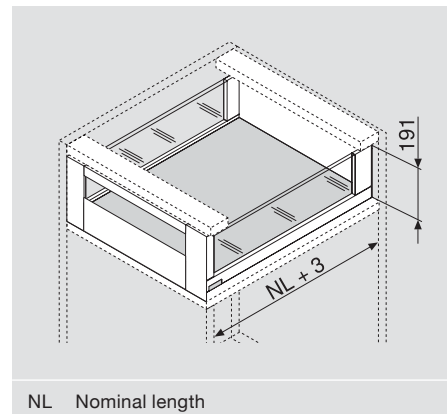
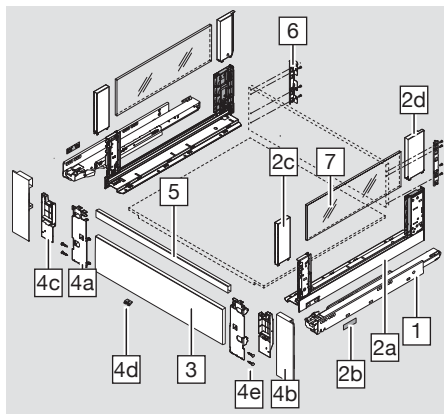

Order specification

1	Cabinet profiles left/right								
	Nominal length	BLUMOTION*				TIP-ON BLUMOTION			
	450 mm	40 kg	750.4501B	70 kg	753.4501B	40 kg	750.4501M	70 kg	753.4501M
	500 mm	40 kg	750.5001B	70 kg	753.5001B	40 kg	750.5001M	70 kg	753.5001M
	550 mm			70 kg	753.5501B			70 kg	753.5501M

2	Drawer side set				
		Consisting of:			
2a		drawer side left/right			
2b		cover caps (external)			
2c		BOXCOVER front			
2d		BOXCOVER back			
Colour variants					
		SW-M	OG-M	TS-M	INGL
Nominal length		Steel			Stainless steel**
450 mm	780C4502S			780C4502I	
500 mm	780C5002S			780C5002I	
550 mm	780C5502S			780C5502I	

3	Front piece without groove			
		Colour variants		
SW-M		OG-M	TS-M	INGL
Aluminium				
For cutting to size	ZV7.1043C01			
Cutting	LW - 126 mm	LW Inner cabinet width		

* Suitable for SERVO-DRIVE

** With anti-fingerprint coating

For planning, assembly, installation and adjustment information please refer to Blum's trade catalogue, DYNALOG planning and ordering software, Blum Product Configurator and/or our EASY ASSEMBLY App.

Inner pull-out – height C – front piece with gallery

LEGRABOX free



Order specification

4		Front piece set			
	Consisting of:				
	4a	Front fixing left/right			
	4b	Outer cover caps left/right			
	4c	Interior cover cap left/right			
	4d	Locking piece			
	4e	Screws			
		Colour variants			
		SW-M	OG-M	TS-M	INGL
		Steel		Stainless steel*	
		Z17.3CS0		Z17.3CI0	

5		Cross gallery		
	Colour variants			
	SW-M	OG-M	TS-M	Nickel Matt
	Aluminium			
	For cutting to size	ZR7.1080U		
	Cutting			
LW - 90 mm				
LW Inner cabinet width				

6		Wooden back fixing brackets left/right		
	Colour variants			
	SW-M	OG-M	TS-M	Nickel
	Steel			
	Height C	ZB7C000S		

7		Glass design element (side)	
	Nominal length		
	450 mm	1 x	ZE7S338G
	500 mm	1 x	ZE7S388G
	550 mm	1 x	ZE7S438G

Accessories

Transportation lock for design element (side)	
	For transporting pre-assembled design elements (side)
	2 x 780C0009

Fixing screws for wooden back fixings and drawer sides with drawer base	
	Ø 4 x 15 mm
In order to achieve optimal assembly, we recommend that you use flat headed screws.	

SERVO-DRIVE applications	
	For additional components required for SERVO-DRIVE applications refer to page 68

TIP-ON BLUMOTION	
	For additional components required for TIP-ON BLUMOTION applications refer to page 69

* With anti-fingerprint coating

LEGRABOX pure



High fronted pull-out – height F

Product

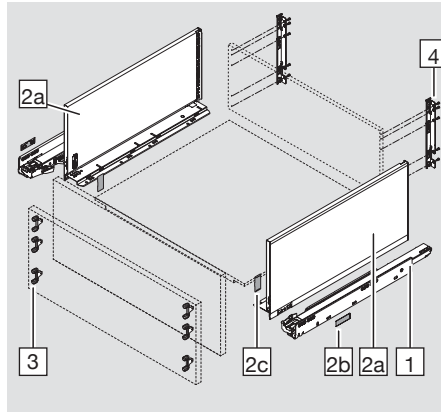

Order specification

1	Cabinet profiles left/right								
	Nominal length	BLUMOTION*				TIP-ON BLUMOTION			
	450 mm	40 kg	750.4501B	70 kg	753.4501B	40 kg	750.4501M	70 kg	753.4501M
	500 mm	40 kg	750.5001B	70 kg	753.5001B	40 kg	750.5001M	70 kg	753.5001M
	550 mm			70 kg	753.5501B			70 kg	753.5501M
	600 mm			70 kg	753.6001B			70 kg	753.6001M

2	Drawer side set			
		Consisting of:		
2a		drawer side left/right		
2b		cover caps (external)		
2c		cover caps (internal)		
		Colour variants		
		SW-M	OG-M	TS-M
		Steel		
		Nominal length		
	450 mm	770F4502S		
	500 mm	770F5002S		
	550 mm	770F5502S		
	600 mm	770F6002S		

3	Front fixing bracket		
	EXPANDO		6 x ZF7M70E2
	Screw-on		6 x ZF7M7002

* Suitable for SERVO-DRIVE

High fronted pull-out – height F

LEGRABOX pure



	4 Wooden back fixings bracket left/right		
	Colour variants		
	SW-M	OG-M	TS-M
	Steel		
Height F	ZB7F000S		

Fixing screws for front fixing brackets	
	Ø 3.5 x 15 mm
	Ø 3.5 x 17 mm
Fixing screws for wooden back fixings and drawer sides with drawer base	
	Ø 4 x 15 mm
	In order to achieve optimal assembly, we recommend that you use flat headed screws.

SERVO-DRIVE applications	
	For additional components required for SERVO-DRIVE applications refer to page 68

TIP-ON BLUMOTION	
	For additional components required for TIP-ON BLUMOTION applications refer to page 69

SERVO-DRIVE for LEGRABOX



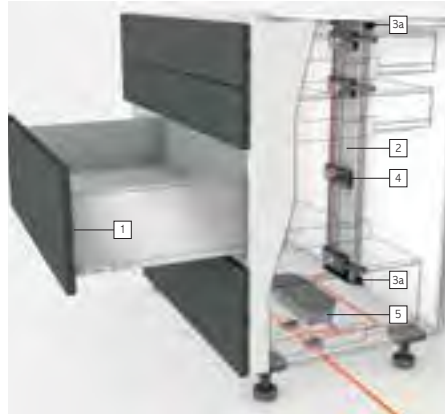

Additional components required for SERVO-DRIVE applications

Product



Order specification

1	Blum distance bumper	
	Diameter	Part number
	Ø 5 mm	993.0530
	Front heights up to 300 mm x 2	
	Front heights greater than 300 mm x 4	





2	Back profile			
	Length	Material	Cable	Part number
	670 mm	Aluminium	With	Z10T670AA
	750 mm	Aluminium	With	Z10T750AA
	1170 mm for cutting to size Internal cabinet height LH – 10 mm	Aluminium	Without	Z10T1170A

3a	Bracket profile attachment top/bottom		
	Material	Colour	Part number
	Nylon	Dust grey	Z10D01E0.01
	Cross bar construction horizontal		

Alternative to 3a

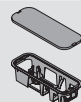
3b	Bracket profile attachment lower/back		
	Material	Colour	Part number
	Nylon	Dust grey	Z10D01EA.01
	Cross bar construction vertical		

4	SERVO-DRIVE drive unit for drawers		
	Material	Colour	Part number
	Nylon	Dust grey	Z10A3000.03
	One SERVO-DRIVE drive unit required per drawer/pull-out		
Additional accessories depending on installation application			

5	Blum transformer*		
	Blum transformer 24W		Z10NE030D
	Flex		Z10M200K
	Transformer unit housing for cabinet base fixing	1x	Z10NG000
	Alternative: Transformer unit housing for panel fixing	1x	Z10NG120
	Connecting node (1x), Cable end protector (2x)		Z10V100E.01
	SERVO-DRIVE cable 8m** for cutting to size		Z10K800AE
	Cable holder		Z10K0009

*SERVO-DRIVE applications require a transformer for power supply. One transformer can connect up to 50 drawers/pull-outs.

**The SERVO-DRIVE cable can be used with a connecting node to extend the power supply cable.

For planning, assembly, installation and adjustment information please refer to Blum's trade catalogue, DYNALOG planning and ordering software, Blum Product Configurator and/or our EASY ASSEMBLY App.

Additional components required for TIP-ON BLUMOTION applications

TIP-ON BLUMOTION for LEGRABOX



Product

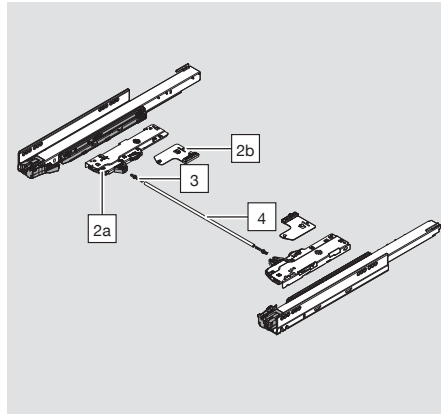

Order specification

2a + 2b	Set containing TIP-ON BLUMOTION unit and TIP-ON BLUMOTION latch									
	Can be used for:			Recommended weight ranges* for an optimum opening and closing function						
	Nominal length (NL)	Unit	Part number	< 10 kg	20 kg	30 kg	40 kg	50 kg	60 kg	70 kg
	270 mm	S0	T60L7040	≤ 10						
		S1	T60L7140		> 10-20					
	350 – 600 mm	L1**	T60L7340		≤ 20					
	L3	T60L7540				15 – 40				
	L5	T60L7570						35 – 70		

3	TIP-ON BLUMOTION synchronisation adapter	
	Symmetrical, in combination with synchronisation linkage, two items required per synchronisation linkage, for internal cabinet width ≥ 294 mm	T60.000D

4	TIP-ON BLUMOTION round synchronisation linkage for cutting to size	
	Possible for cabinet widths ≥ 287 mm Suitable for cabinet widths of up to 1400 mm	T60.1125W

Accessories

	Front gap template for TIP-ON BLUMOTION LEGRABOX / MOVENTO	
	Setting the front gap to 2.5 mm	65.5631

* Total weight of the pull-out

** L1 cannot be used with a 70kg cabinet profile and only to be used with a 40kg cabinet profile.

LEGRABOX pure



Sink Cabinet - height M

Product

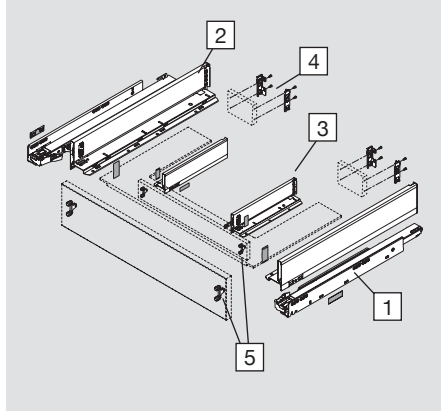
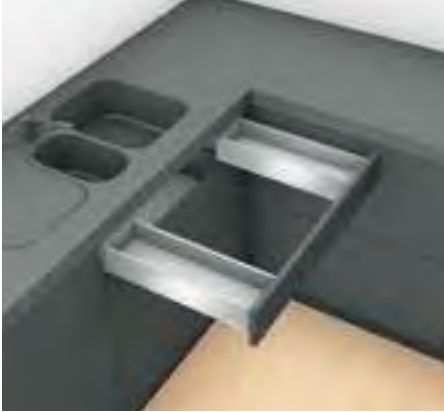

Components required

1	Cabinet profiles left/right
2	Exterior - drawer side set M height including external and internal cover caps
3	Interior - drawer side set M height including external and internal cover caps
4	Wooden back fixing brackets M height x 4
5	Front fixing bracket x 4

Recommended combination of nominal lengths for sink drawer

1,2	Exterior - Drawer side set and cabinet profiles	3	Interior - Drawer side set and cabinet profiles
	Nominal length		Nominal length
	400 mm		270 mm
	450 mm		270 mm
	500 mm		350 mm
	550 mm		400 mm
	600 mm		450 mm

Order specification

1	Cabinet profiles left/right				
	Nominal length	BLUMOTION*			
	400 mm	40 kg	750.4001B		
	450 mm	40 kg	750.4501B	70 kg	753.4501B
	500 mm	40 kg	750.5001B	70 kg	753.5001B
	550 mm			70 kg	753.5501B
	600 mm			70 kg	753.6001B

* Suitable for SERVO-DRIVE

Sink Cabinet - height M

LEGRABOX pure



2	Drawer side set				
	Consisting of:				
	2a drawer side left/right				
	2b cover caps (external)				
	2c cover caps (internal)				
	Colour variants				
		SW-M	OG-M	TS-M	INGL
	Nominal length	Steel			Stainless steel**
	270 mm	770M2702S			
	350 mm	770M3502S			
	400 mm	770M4002S			770M4002I
450 mm	770M4502S			770M4502I	
500 mm	770M5002S			770M5002I	
550 mm	770M5502S			770M5502I	
600 mm	770M6002S				

4	Wooden back fixing brackets left/right				
	Colour variants				
		SW-M	OG-M	TS-M	Nickel
		Steel			
Height M	ZB7M000S				

5	Front fixing bracket				
	EXPANDO			4 x	ZF7M70E2
	Screw-on			4 x	ZF7M7002

** With anti-fingerprint coating

LEGRABOX pure
LEGRABOX free



Sink Cabinet - height C

Product

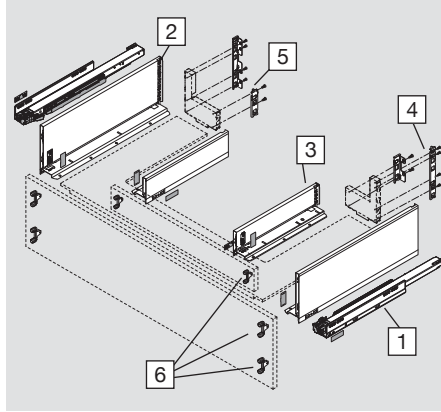

Components required

1	Cabinet profiles left/right
2	Exterior - drawer side set C height including external and internal cover caps
3	Interior - drawer side set M height including external and internal cover caps
4	Wooden back fixing brackets C height x 2
5	Wooden back fixing brackets M height x 2
6	Front fixing bracket x 8

Recommended combination of nominal lengths for sink drawer

1,2	Exterior - Drawer side set and cabinet profiles	3	Interior - Drawer side set and cabinet profiles
	Nominal length		Nominal length
	400 mm		270 mm
	450 mm		270 mm
	500 mm		350 mm
	550 mm		400 mm
	600 mm		450 mm

Order specification

1	Cabinet profiles left/right			
	Nominal length	BLUMOTION**		
	400 mm	40 kg	750.4001B	
	450 mm	40 kg	750.4501B	70 kg
	500 mm	40 kg	750.5001B	70 kg
	550 mm			70 kg
	600 mm			70 kg
				753.4501B
				753.5001B
				753.5501B
				753.6001B

* Incl. 2 mm tilt adjustment

** Suitable for SERVO-DRIVE

Sink Cabinet - height C

LEGRABOX pure
LEGRABOX free



2		Drawer side set - LEGRABOX pure				
	Consisting of:					
	2a	drawer side left/right				
	2b	cover caps (external)				
	2c	cover caps (internal)				
			Colour variants			
			SW-M	OG-M	TS-M	INGL
	Nominal length		Steel			Stainless steel**
	400 mm		770C4002S			770C4002I
	450 mm		770C4502S			770C4502I
	500 mm		770C5002S			770C5002I
550 mm		770C5502S			770C5502I	
600 mm		770C6002S				

2b		Alternative to 2 Drawer side set - LEGRABOX free				
	Consisting of:					
	2a	drawer side left/right				
	2b	cover caps (external)				
	2c	BOXCOVER front				
	2d	BOXCOVER back				
			Colour variants			
			SW-M	OG-M	TS-M	INGL
	Nominal length		Steel			Stainless steel**
	450 mm		780C4502S			
	500 mm		780C5002S			
550 mm		780C5502S			780C5502I	

2b		Glass design element (side)			
	Nominal length				
	450 mm	1 x	ZE7S338G		
	500 mm	1 x	ZE7S388G		
	550 mm	1 x	ZE7S438G		

3		Drawer side set				
	Consisting of:					
	2a	drawer side left/right				
	2b	cover caps (external)				
	2c	cover caps (internal)				
			Colour variants			
			SW-M	OG-M	TS-M	INGL
	Nominal length		Steel			Stainless steel**
	270 mm		770M2702S			
	350 mm		770M3502S			
	400 mm		770M4002S			770M4002I
450 mm		770M4502S				

LEGRABOX pure
LEGRABOX free



Sink Cabinet - height C

	4	Wooden back fixing brackets left/right				
			Colour variants			
			SW-M	OG-M	TS-M	Nickel
			Steel			
	Height C		ZB7C000S			

	5	Wooden back fixing brackets left/right				
			Colour variants			
			SW-M	OG-M	TS-M	Nickel
			Steel			
	Height M		ZB7M000S			

	6	Front fixing bracket			
		EXPANDO		6 x	ZF7M70E2
		Screw-on		6 x	ZF7M7002

** With anti-fingerprint coating

SPACE TOWER

LEGRABOX pure
LEGRABOX free



Product



Recommended configuration

- Shelf
- Inner drawer – M height
- Inner pull-out with low glass – C height x 2
- Inner pull-out with high glass – C height x 2
- Zero protrusion hinge with BLUMOTION or TIP-ON for doors
- Cabinet width 300 mm – 600 mm x 1 door
- Cabinet width 600 mm – 1200 mm x 2 doors

Order Specification

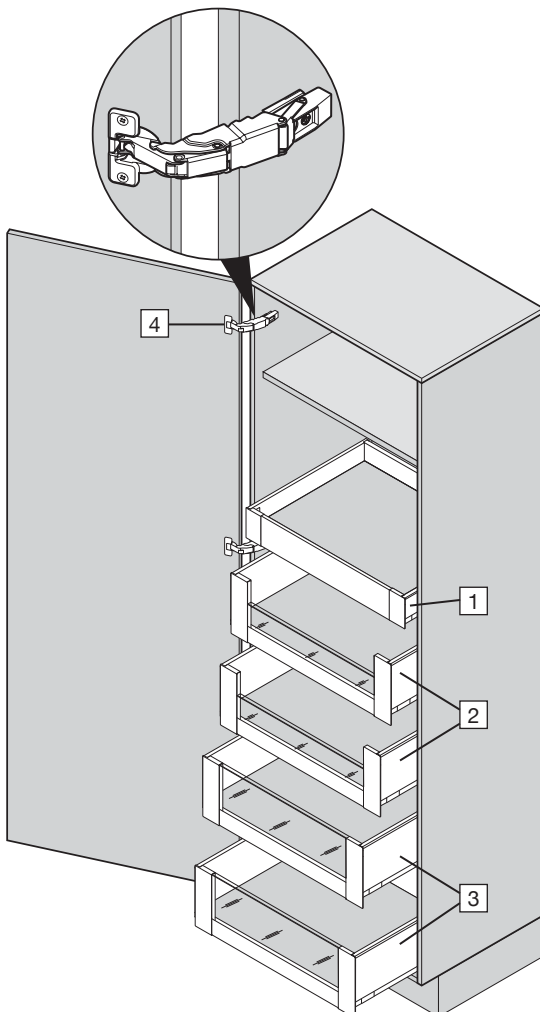

LEGRABOX pure	SPACE TOWER elements	Order specification and planning information
1	Inner drawer – M height	Refer to page 49
2	Inner pull-out – C height with low glass	Refer to page 55
3	Inner pull-out – C height with low glass	Refer to page 55
4	SPACE TOWER cabinet front – zero protrusion hinge	Refer to page 76

LEGRABOX free	SPACE TOWER elements	Order specification and planning information
1	Inner drawer – M height	Refer to page 49
2	Inner pull-out – C height with low glass	Refer to page 61
3	Inner pull-out – C height with low glass	Refer to page 61
4	SPACE TOWER cabinet front – zero protrusion hinge	Refer to page 76

LEGRABOX pure
LEGRABOX free



SPACE TOWER

Order Specification

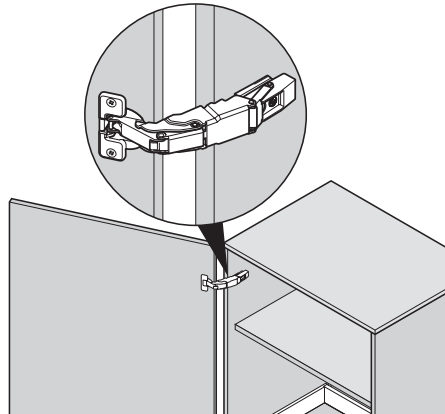

1	155° zero protrusion hinge	Zinc boss with spring*		Zinc boss unsprung**	
	Overlay application	INSERTA	71T7540N	INSERTA	70T7540NTL
		Screw-on	71T7500N	Screw-on	70T7500NTL
	Dual application	INSERTA	71T7640N		
	Inset application Use hinges for dual application and a 9mm spaced mounting plate.				

2	Mounting Plate			
		Spacing	Height	Part Number
	Horizontal cam mounting plate (EXPANDO)	0 mm	8.5 mm	177H3100E
		3 mm	11.5 mm	177H3130E
	Horizontal cam mounting plate	0 mm	8.5 mm	175H3100
	Horizontal cam mounting plate (EXPANDO)	0 mm	8.5 mm	174E6100.01
		3 mm	11.5 mm	174E6130.01
	Horizontal cam mounting plate	0 mm	8.5 mm	173H7100
		3 mm	11.5 mm	173H7130

3	BLUMOTION (optional)
	BLUMOTION 973A





* Suitable for BLUMOTION

** Suitable for TIP-ON for doors

SPACE TOWER

LEGRABOX pure
LEGRABOX free



4		TIP-ON for doors	
		Colour variants	
		SW	TS
 <p>For drilling</p> <p>For overlay doors up to approx. 1300mm in height. For unsprung hinges Rec. for AVENTOS HK-XS. For drilling Ø10x50mm. Short version, length 50mm incl. 1 x glue-on and 1 x screw-on catch plates.</p>	Short version with magnet	965.1004	
		 <p>With inline adaptor plate</p> <p>Assembly using chipboard screws Ø3.5mm or Ø4mm or with system screws. For use in combination with TIP-ON short version.</p>	965.1201
 <p>For drilling</p> <p>For overlay doors starting from approx. 1300mm in height. For unsprung hinges. For drilling Ø10x76mm. Long version, length 76mm incl. 1 x glue-on and 1 x screw-on catch plates.</p>	Long version with magnet	956A1004	
		 <p>With inline adapter plate</p> <p>Assembly using chipboard screws Ø3.5mm or Ø4mm or with system screws. For use in combination with TIP-ON long version.</p>	956A1004

LEGRABOX pure
LEGRABOX free



Narrow Cabinet Application

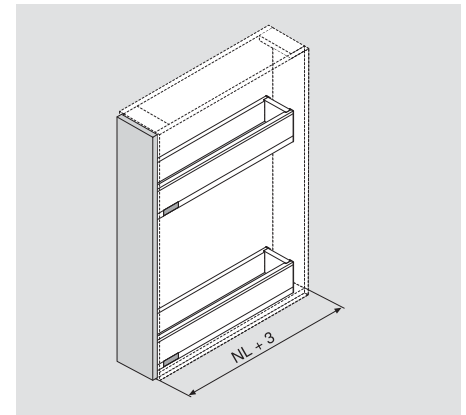
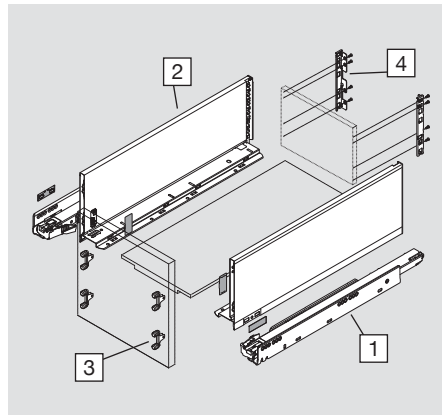

Components required

1	Cabinet profiles left/right x 1
2a	Drawer side set – M height x 1
2b	Drawer side set – C height x 1
3	Front fixing bracket x 6
4a	Wooden back fixing brackets – M height x 2
4b	Wooden back fixing brackets – C height x 2

Order specification

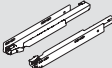

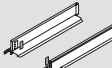
1	Cabinet profiles left/right				
	Nominal length	BLUMOTION			
	350 mm	40 kg	750.3501B		
	400 mm	40 kg	750.4001B		
	450 mm	40 kg	750.4501B	70 kg	753.4501B
	500 mm	40 kg	750.5001B	70 kg	753.5001B
	550 mm			70 kg	753.5501B
	600 mm			70 kg	753.6001B

2	LEGRABOX pure M height					
	Consisting of:					
	2a	drawer side left/right				
	2b	customer branding				
	2c	cover caps				
			Colour variants			
			SW-M	OG-M	TS-M	INGL
	Nominal length		Steel			Stainless steel**
	350 mm	770M3502S				
	400 mm	770M4002S			770M4002I	
	450 mm	770M4502S			770M4502I	
500 mm	770M5002S			770M5002I		
550 mm	770M5502S			770M5502I		
600 mm	770M6002S					

Narrow Cabinet Application

LEGRABOX pure
LEGRABOX free

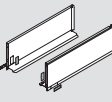
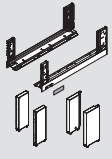
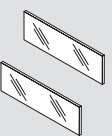

2b	Drawer side set - LEGRABOX pure C height				
	Consisting of:				
	2a	drawer side left/right			
	2b	customer branding			
	2c	cover caps			
		Colour variants			
		SW-M	OG-M	TS-M	INGL
	Nominal length	Steel			Stainless steel**
	350 mm	770C3502S			
	400 mm	770C4002S			770C4002I
	450 mm	770C4502S			770C4502I
500 mm	770C5002S			770C5002I	
550 mm	770C5502S			770C5502I	
600 mm	770C6002S				
2b	Alternative to 2 Drawer side set - LEGRABOX free				
	Consisting of:				
	2a	drawer side left/right			
	2b	customer branding			
	2c	BOXCOVER front			
	2d	BOXCOVER back			
		Colour variants			
		SW-M	OG-M	TS-M	INGL
Nominal length	Steel			Stainless steel**	
450 mm	780C4502S			780C4502I	
500 mm	780C5002S			780C5002I	
550 mm	780C5502S			780C5502I	
2b	Glass design element (side) for LEGRABOX free				
	Nominal length				
	450 mm	1 x	ZE7S338G		
	500 mm	1 x	ZE7S388G		
	550 mm	1 x	ZE7S438G		
3	Front fixing bracket				
	EXPANDO		6 x	ZF7M70E2	
	Screw-on		6 x	ZF7M7002	
4	Wooden back fixing brackets left/right				
		Colour variants			
		SW-M	OG-M	TS-M	Nickel
		Steel			
Height M		ZB7M000S			
Height C		ZB7C000S			

** With anti-fingerprint coating

For planning, assembly, installation and adjustment information please refer to Blum's trade catalogue, DYNALOG planning and ordering software, Blum Product Configurator and/or our EASY ASSEMBLY App.

LEGRABOX pure
LEGRABOX free



Accessories

Side stabiliser

Product

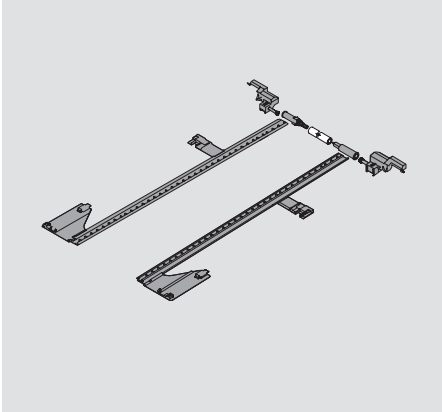

- Additional stabilisation for extra wide pull-outs
- Recommendation:
Cabinet width 900 up to 1400 mm
- Aluminium shaft suitable for KB 1400 mm,
for cutting to size
- Suitable for use in combination with
BLUMOTION, SERVO-DRIVE and TIP-ON
BLUMOTION applications.
- No additional space requirement at the bottom.

Order specification

1	Side stabiliser	
	Nominal length	
	270–400 mm	ZS7M400LU
	450–600 mm	ZS7M650LU
	Shaft cutting	
	LW - 295 mm	
	Toothed strip cutting	
	NL + 10 mm	
LW Inner cabinet width		
NL Nominal length		

Base stabiliser

Product

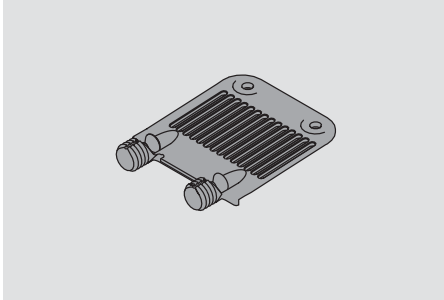

Base stabiliser	
For stabilising wide drawer bases	Z961.10E1
Reinforces the connection between the base and the front	
Recommendation: from cabinet width of 900 mm, 1 piece	

TORX screwdriver

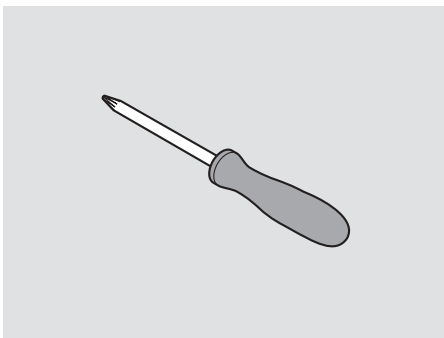

TORX screwdriver	
Short TORX screwdriver Blade length of 35 mm	SR-DREHTX20 35
Long TORX screwdriver Blade length of 100 mm	SD-DREHTX20 100
TORX size 20 (T20)	
Required for adjusting drawer/pull-out	
Short and long options available to facilitate easy adjustment of drawers and pull-outs of all sizes, narrow or wide.	

LEGRABOX pure
LEGRABOX free



Assembly devices

Base router



Base router

Device that ensures easy and precise rebating of the LEGRABOX pure drawer/pull-out base.

M35.7200

No set up required.

Suitable for drawer side lengths 270 mm – 600 mm.

Suitable for 16 mm base thicknesses.

Components

1 x Base router machine, 1 x fixing board, 1 x stop bar, 1 x support stop, 1 x cutter DM 44, 1 x depth stop, 1 x timber stop.

MINIPRESS P



Blum's drilling and fittings insertion specialist facilitating simple construction of cabinets and drawers.

M53.1050

Provides fast, accurate and easy drilling insertion for cabinet profiles, mounting plates, adaptor plates, hinges and drawer fronts.

Functions pneumatically.

Thanks to a simple flip chart, adjustments to the machines can be completed quickly and effortlessly.

For LEGRABOX pure drilling the New MINISTICK is required. This can be easily retro fitted onto existing MINIPRESS P machines.

MINISTICK (new)



MINISTICK (new)

Facilitates easy and precise drilling for LEGRABOX pure when using Blum's MINIPRESS P (required).

MZS.0050

Retro fit option.

New MINISTICK charts available for usage support.

Also suitable for TANDEMBOX, runner, hinge and mounting plate drilling.

Stop system for MINISTICK.

*Required for MINIPRESS P purchased prior to 2005.

M30N0200

BOXFIX E-L

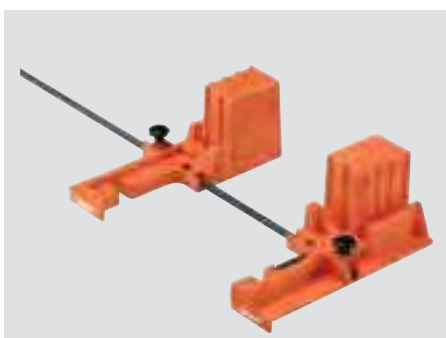

BOXFIX E-L

Provides simple yet precise manual assembly of LEGRABOX drawers and pull-outs.

ZMM.0700

Provides optimal support. The LEGRABOX pure drawer/pull-out parts can be assembled precisely and seamlessly without any awkward holding.

Easily transported; can be used onsite or in the workshop.

Can be used to assemble a range of drawer sizes; nominal lengths of 270 mm – 600 mm, cabinet widths from 250 mm – 1200 mm

Drilling template for LEGRABOX (back and base)



Drilling template for LEGRABOX	
Template for pre-drilling the fixing holes for LEGRABOX pure drawer/pull-out base width and back.	ZML.700
Ensures exact pre-drilling of the base and back.	
Easily transported; can be used onsite or in the workshop.	
Components	
1 x template, 1 x drilling stop, 1 x allen key	

Universal drilling template (drawer front)



Universal drilling template	
The multifunctional template that combines high precision with practical value.	ZML.0040.01
Facilitates exact marking and pre-drilling positions for front fixing and drawer/pull-out back and base.	
Calibrated for easy adjustment.	
Suitable for LEGRABOX pure, TANDEMBOX drawer systems, MOVENTO, TANDEM and METABOX.	
Components	
1 x Universal drilling template, 1 x drilling depth stop (ø 10 mm), 1 x drilling depth stop (ø 5 mm), 1 x marking template (ø 10 mm), 1 x marking template (ø 5 mm).	

Universal drilling template (cabinet profile)



Universal drilling template	
Facilitates pre-drilling of the fixing positions for cabinet profiles.	65.1000.01
Can be used with assembled and flat pack cabinets.	
Calibrated for setting the height and depth position.	
Suitable for LEGRABOX pure, TANDEMBOX drawer systems, MOVENTO, TANDEM and METABOX.	
Components	
1 x Extension rail 1000 mm, 4 x universal drilling template, 1 x drilling depth spacer Ø 5 mm, 1 x reducing bush Ø 5 to Ø 2.5 mm, 1 x allen key.	

AMBIA-LINE



Overview of materials and colour

Steel design



Recommended colour combinations	AMBIA-LINE colours		
	OG-M	TS-M	SW-M
LEGRABOX colours	Orion Grey Matt	Terra Black Matt	Silk White Matt
OG-M	■		
TS-M		■	
SW-M			■
OG-M			
Orion Grey Matt			
TS-M			
Terra Black Matt			
SW-M			
Silk White Matt			

Cutlery insert



For LEGRABOX applications in Anti-fingerprint Stainless Steel we recommend selecting AMBIA-LINE in Terra Black Matt or Orion Grey Matt.

Steel design





AMBIA-LINE





Drawer



Order specification for drawer height M and height K

Cutlery insert			OG-M	TS-M	SW-M/OG-M
	Nominal length	Width			
	450 mm	300 mm	ZC7S450BS3		
	500 mm	300 mm	ZC7S500BS3		
	550 mm	300 mm	ZC7S550BS3		
	600 mm	300 mm	ZC7S600BS3		
Adapter profile not required for cutlery insert					

Drawer frame for nominal lengths of 270 mm or more					
	Nominal length	Width	OG-M	TS-M	SW-M
	from 270 mm	242 mm	ZC7S300RSU		
With magnet for connection to the adapter profile or drawer side					

Adapter profile for connection to chipboard back					
	Height	Width	OG-M	TS-M	SW-M
	M	242 mm	ZC7A0U0M		
	K	242 mm	ZC7A0U0K		
Not required for NL 270					
Recommended for NL greater than 350 mm					
Required for all LEGRABOX free and LEGRABOX pure in Anti-fingerprint Stainless Steel applications.					

Individual cross divider (optional)					
	Height	for width	OG-M	TS-M	SW-M
	50 mm	242 mm	ZC7Q0U0SS		

For planning, assembly, installation and adjustment information please refer to Blum's trade catalogue, DYNALOG planning and ordering software, Blum Product Configurator and/or our EASY ASSEMBLY App.

AMBIA-LINE





Steel design

Drawer





Drawer frame – narrow

		OG-M	TS-M	SW-M
	Nominal length			
	Width			
	450 mm	ZC7S450RS1		
	500 mm	ZC7S500RS1		
	550 mm	ZC7S550RS1		
	600 mm	ZC7S600RS1		

Individual cross divider (optional)

		OG-M	TS-M	SW-M
	Height			
	for width			
	50 mm	ZC7Q010SS		

Drawer frame – wide

		OG-M	TS-M	SW-M
	Nominal length			
	Width			
	450 mm	ZC7S450RS2		
	500 mm	ZC7S500RS2		
	550 mm	ZC7S550RS2		
	600 mm	ZC7S600RS2		

Individual cross divider (optional)

		OG-M	TS-M	SW-M
	Height			
	for width			
	50 mm	ZC7Q020SS		

For planning, assembly, installation and adjustment information please refer to Blum's trade catalogue, DYNALOG planning and ordering software, Blum Product Configurator and/or our EASY ASSEMBLY App.

Steel design

AMBIA-LINE





High fronted pull-out



Order specification for high fronted pull-out height C and height F

High fronted pull-out frame for nominal lengths of 270 mm or more					
	Nominal length	Width	OG-M	TS-M	SW-M
		from 270 mm	242 mm	ZC7F300RSU	
With magnet for connection to the adapter profile or drawer side					

Adapter profile for connection to chipboard back					
	Height	Width	OG-M	TS-M	SW-M
		C	242 mm	ZC7A0U0C	
Not required for NL 270 and 300 mm					
Recommended for NL greater than 350 mm					
Required for all LEGRABOX free and LEGRABOX pure in Anti-fingerprint Stainless Steel applications.					

Individual cross divider (optional)					
	Height	for width	OG-M	TS-M	SW-M
		110 mm	242 mm	ZC7Q0U0FS	
	110 mm	218 mm	ZC7Q0P0FS		

High fronted pull-out frame for nominal lengths of 400 mm or more					
	Nominal length	Width	OG-M	TS-M	SW-M
		from 400 mm	218 mm	ZC7F400RSP	
With magnet for connection to the adapter profile or drawer side					

AMBIA-LINE



Steel design

Adapter profile for connection to chipboard back

	Height	Width	OG-M	TS-M	SW-M
C		218 mm		ZC7A0P0C	
F		218 mm		ZC7A0P0F	

Required for all LEGRABOX free and LEGRABOX pure in Anti-fingerprint Stainless Steel applications.

Steel design

AMBIA-LINE





High fronted pull-out

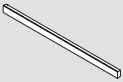

Order specification for high fronted pull-out height C and height F

Cross gallery for cutting to size		OG-M	TS-M	SW-M
	Length 1080 mm	ZR7.1080U		
	Cutting: LW-90 mm LW = inner cabinet width			

Connectors		OG-M	TS-M	SW-M
	LEGRABOX pure	ZC7U10E0		
	LEGRABOX free	ZC7U11E0		

Lateral divider		OG-M	TS-M	SW-M
	Length 84 mm	ZC7U10F0		

For planning, assembly, installation and adjustment information please refer to Blum's trade catalogue, DYNALOG planning and ordering software, Blum Product Configurator and/or our EASY ASSEMBLY App.

AMBIA-LINE



Steel design

AMBIA-LINE bottle set



Order specification

	Nominal length	Width	OG-M	TS-M	SW-M
	from 450 mm	100 mm	ZC7B0100S		
	from 450 mm	200 mm	ZC7B0200S		

Not suitable for inner pull-outs

Drawer frame – narrow					
	Nominal length	Width	OG-M	TS-M	SW-M
	450 mm	100 mm	ZC7S450RS1		
	500 mm	100 mm	ZC7S500RS1		
	550 mm	100 mm	ZC7S550RS1		
	600 mm	100 mm	ZC7S600RS1		

Drawer frame – wide					
	Nominal length	Width	OG-M	TS-M	SW-M
	450 mm	200 mm	ZC7S450RS2		
	500 mm	200 mm	ZC7S500RS2		
	550 mm	200 mm	ZC7S550RS2		
	600 mm	200 mm	ZC7S600RS2		

For planning, assembly, installation and adjustment information please refer to Blum's trade catalogue, DYNALOG planning and ordering software, Blum Product Configurator and/or our EASY ASSEMBLY App.



Order specification

Knife holder			
	Length	Width	
	409 mm	186 mm	
	For 9 knives		OG-M
	For drawer height M and height K		ZC7M0200
	Nominal length from 450 mm and greater		
Foil/film dispenser			
	Length	Width	
	409 mm	187 mm	
	Double unit, cling film and aluminium foil, without film/foil		OG-M
	Compatible with foil / cling film with dimensions: Diameter 46 mm and length 330 mm.		ZC7C0001
	For drawer height M and height K		
	Nominal length from 450 mm and greater		
Spice holder			
	Length	Width	
	356 mm	200 mm	OG-M
	For high fronted pull-out height C and height F		ZC7G0P01
	Suitable for use with ZC7F400RSP		
Blum Plate holder			
	Plate diameter	Stacking height	
	186–322 mm	up to 12 plates (146 mm)	OG-M
	Overall Plate Holder height: 170 mm		ZC7T0350
	For high fronted pull-out height C and height F		

For planning, assembly, installation and adjustment information please refer to Blum's trade catalogue, DYNALOG planning and ordering software, Blum Product Configurator and/or our EASY ASSEMBLY App.

Blum

Founded over 60 years ago by Julius Blum, today Blum is an internationally active family-owned company. Blum is trusted and renowned worldwide for designing a comprehensive range of high quality industry leading products that significantly enhance user convenience and ergonomics in the kitchen and throughout the home. That's why we make every effort to perfect the motion of our lift, hinge, box and runner systems.





Design is more than an attractive appearance

Form, function and the focus on perfecting motion are and have always been firmly interlinked at Blum. This means that Blum products turn the use of high-quality furniture into a true experience and offer the ideal fitting solution for every home. Blum incorporates current design trends, personal preferences and functional furniture use. Blum fittings are internationally recognised for their sophisticated design and functional excellence.



Quality for the lifetime of the furniture

For over 60 years, quality has been the highest principle for the development and manufacture of Blum products. Our fittings exemplify quality with their well-thought-out function and durability, engineered to provide problem free use for the lifetime of the furniture. We achieve this by using the strictest internal guidelines and rigorous testing that form the basis of our ISO9001 Quality Management System.



Innovation for high living comfort

We want our fitting solutions to be innovative and make everyday kitchen use easier. That's why our developments are based on findings from requirements research and input from our customers. Blum is one of the largest patent applicants in Austria and has more than 1,000 registered trademarks. CLIP, tool free assembly, TANDEM technology, MOVENTO technology, LEGRABOX Box system, BLUMOTION soft close, SERVO-DRIVE electrical motion support system and TIP-ON BLUMOTION mechanical motion support system are all innovations by Blum and milestones in the furniture manufacturing industry.



Our contribution to the environment

Blum strives to minimise its environmental impact with environmental protection being an integral part of everything we do. We use environmentally friendly processes, use raw materials intelligently and save energy wherever we can. Our commitment to environmental protection is internationally recognised and rewarded. We endeavour to maintain and are always looking to improve our environmental management systems.





ISO 50001

Certified Energy
System



ISO 9001

Certified Quality
System



ISO 14001

Certified Environmental
System

Blum Showrooms

Sydney (Head Office)

10 Blackbird Close
Len Waters Estate NSW 2170
Ph: 02 9612 5400

Adelaide

179 Railway Terrace
Mile End SA 5031
Ph: 08 8118 6070

Brisbane

6/39-45 Compton Road
Underwood QLD 4119
Ph: 07 3135 9490

Melbourne

245 Ferntree Gully Road
Mount Waverley VIC 3149
Ph: 03 9982 1720

Perth

3/50 Howe Street
Osborne Park WA 6916
Ph: 08 6467 0110

Place distributor or company contact details here.

Blum Australia Pty. Ltd.

P.O. Box 1615

Green Valley NSW 2168

Toll Free: 1800 179 186

E-Mail: info.au@blum.com

 **blum**®